

# Contents

1. Safety Precautions - Read Before Using.....	3
1.1 Symbol Usage.....	3
1.2 Induction Heating Hazards Symbols Instructions and Precautions.....	3
1.3 Additional Symbols for Installation, Operation, and Maintenance.....	5
1.4 Definition.....	7
2. Safety Instructions and Maintenance.....	8
2.1 Safety Instructions.....	8
2.2 Routine Maintenance.....	8
3. Type and Specification.....	9
3.1 Unpacking Inspection.....	9
3.2 Specification.....	9
3.3 Commissioning before Starting.....	9
4. Installation and Wiring.....	10
4.1 Installation Condition and Dismantle Cautions.....	10
4.2 Equipment Wiring Notices.....	10
4.3 Equipment Appearance and Wiring.....	10
5. Display and Operation Control.....	12
5.1 Safety Equipment.....	16
5.2 LCD Keyboard Instructions.....	16
5.3 Indicator and Display Mode.....	18
5.4 Parameter Screen Display and Set.....	19
5.4.1 System Set Screen.....	19
5.4.2 Control Mode Set Screen.....	20
5.4.2.1 Temperature Control.....	20
5.4.2.1.1 Constant Temp.....	21
5.4.2.1.2 Bake-Out.....	21
5.4.2.1.3 HT (Heat Treatment).....	22
5.4.2.1.4 Custom.....	23
5.4.2.2 Power Control.....	26
5.4.2.2.1 Constant Power.....	26
5.4.2.2.2 Power vs Time.....	27
5.4.3 Running Status Screen.....	28
5.4.3.1 Temperature Control Status Screen.....	28
5.4.3.2 Power Control Status Screen.....	29
5.4.4 Custom Segment Record Interface.....	30
5.4.5 Monitoring Parameters, Fault Code Record Display.....	31
5.4.6 Basic Parameters Display.....	32
5.4.7 Fault Alarm Screen Display.....	36
5.5 Hold Button (constant temperature/constant power) function.....	36
5.6 Code Set and Check.....	36
6. Function Instruction.....	38
6.1 Parameters Initialization Function (P0.03).....	38
6.2 Temperature Control Option Parameters (P2.03/P2.04).....	38
6.3 Language Choice (P3.05).....	39

---

6.4 TC type selection (P3.06) .....	39
7. Parameter table .....	39
7.1 Basic Parameter Table .....	39
7.2 Monitoring Parameter Table .....	42
8. Protection、Alarm Code and Fault Check .....	43
8.1 Protection and Alarm Code Table .....	43
9. Water Cooling System Operation Manual .....	48
9.1 Function introduction: .....	48
9.2 protection .....	48
9.3 control panel introduction .....	49
9.4 compressor Current and condensing temp.inquiry .....	51
9.5 error output .....	51

## 1. Safety Precautions - Read Before Using



Protect yourself and others from injury - read and follow these precautions

### 1.1 Symbol Usage



**DANGER!** - Indicates a hazardous situation which, if not avoided, will result in death or serious injury. The possible hazards are shown in the adjoining symbols or explained in the text.

**NOTICE** - Indicates statements not related to personal injury.

Indicates special instructions



This group of symbols means Warning! Watch Out! ELECTRIC, SHOCK, MOVING PARTS, and HOT PARTS hazards. Consult symbols and related instructions below for necessary actions to avoid the hazards.

### 1.2 Induction Heating Hazards Symbols Instructions and Precautions



The symbols shown below are used throughout this manual to call attention to and identify possible hazards. When you see the symbol, watch out, and follow the related instructions to avoid the hazard. Please read and follow all Safety Standards.



Only qualified persons should install, operate, maintain and repair this unit.



During operation, keep everybody, especially children, away.



#### **ELECTRIC SHOCK can kill.**

Incorrectly installed or improperly grounded equipment is a hazard.

- \* Do not touch live electrical parts.
- \* Enclose any connecting bus bars and coolant fittings to prevent unintentional contact.
- \* Wear dry, hole-free insulating gloves and body protection.
- \* Insulate yourself from work and ground using dry insulating mats or insulator big enough to prevent any physical contact with the work or ground.
- \* Additional safety precautions are required when any of the following electrically hazardous conditions are present: in damp locations or while wearing wet clothing; on metal structures such as floors, gratings, or scaffolds; when in cramped positions such as sitting, kneeling, or lying; or when there is a high risk of unavoidable or accidental contact with the workpiece or ground. For these conditions, see ANSI Z49.1 listed in Safety Standards. And, do not work alone!
- \* Disconnect input power before installing or servicing this equipment.
- \* Properly install and ground this equipment according to its Owner's manual and national, state, and local codes.
- \* Always verify the supply ground - check and be sure that input power cord

ground wire is properly connected to ground terminal in disconnect box or that cord plug is connected to a properly grounded receptacle outlet.

- \* When making input connections attach proper grounding conductor first-double-check connections.
- \* Keep cords dry, free of oil and grease, and protected from hot metal and sparks.
- \* Frequently inspect input power cord for damage or bare wiring - re-place cord immediately if damaged - bare wiring can kill.
- \* Turn off all equipment when not in use.
- \* Do not use worn, damaged, undersized, or poorly spliced cables.
- \* Do not drape cables end your body.
- \* Do not touch power circuit if you are in contact with the work, ground, or another power circuit from a different machine.
- \* Use only well-maintained equipment. Repair or replace damaged parts at once. Maintain unit according to manual.
- \* Wear a safety harness if working above floor level.
- \* Keep all panels and outer cover securely in place.



significant dc voltage exists in inverter-type power sources after removal of input Power. Turn Off inverter, disconnect input power, and discharge input capacitors according to instructions in Maintenance Section before touching any internal parts.



#### **FUMES AND GASES can be hazardous.**

Induction Heating of certain materials, adhesives, and fluxes can produce fumes and gases. Breathing these fumes and gases can be hazardous to your health.

- \* Keep your head out of the fumes. Do not breathe the fumes.
- \* If inside, ventilate the area and/or use local forced ventilation to re- move fumes and gases.
- \* If ventilation is poor, wear an approved air-supplied respirator.
- \* Read and understand the Material Safety Data Sheets (MSDS) and The manufacturer's instruction for adhesives, fluxes, metals, coatings, cleaners, and degreasers.
- \* Work in a confined space only if it is well ventilated, or while wearing an air-supplied respirator. Always have a trained watch person near-by. Fumes and gases from heating can displace air and lower the oxygen level causing injury or death. Be sure the breathing air is safe.
- \* Do not heat in locations near degreasing, cleaning, or spraying operations. The heat can react with vapors to form highly toxic and irritating gases.
- \* Do not end heat coated metals, such as galvanized, lead, or cadmium Plated steel, unless the coating is removed from the heated area, the area is well ventilated, and while wearing an air- supplied respirator. The coatings and any metals containing these elements can give off toxic fumes if end heated. See coating MSDS for temperature information.



**Fire or explosion hazard**

- \* Watch out overheat parts.
- \* Watch for fire; keep extinguisher nearby.
- \* Keep flammables away from work area.
- \* Do not locate unit on, end, or near combustible surfaces.
- \* Do not install unit near flammables.
- \* Do not operate where the atmosphere may contain flammable dust, gas, or liquid vapors (such as gasoline).
- \* After completion of work, inspect area to ensure it is free of sparks, glowing embers, and flames.
- \* Use only correct fuses or circuit breakers. Do not endsize or by-pass them.



**INDUCTION HEATING can cause burns.**

- \* Hot parts and equipment can injure.
- \* Do not touch or handle induction head/coil during operation.
- \* Do not touch hot parts bare-handed.
- \* Allow cooling period before handling parts or equipment.
- \* Keep metal jewelry and other metal personal items away from coils during operation.

**1.3 Additional Symbols for Installation, Operation, and Maintenance**



**FALLING UNIT can cause injury.**

- \* Use handle and have person of adequate physical strength lift unit.
- \* Move unit with hand cart or similar device.
- \* For units without a handle, use equipment of adequate capacity to lift unit.
- \* When using lift forks to move unit, be sure forks are long enough to extend beyond opposite side of unit.

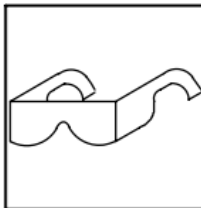

**FLYING METAL OR DIRT can injure eyes.**

- \* Wear approved safety glasses with side shields or wear face shield.



**MOVING PARTS can cause injury.**

- \* Keep away from moving parts such as fans.
- \* Keep all doors, panels, outer cover and guards closed and securely in place.



**MAGNETIC FIELDS can affect Implanted medical devices.**

- \* Wearers of Pacemakers and other Implanted Medical Devices should keep away.
- \* Implanted Medical Device wearers should consult their doctor and the device manufacturer before going near arc welding, spot welding, gouging,

plasma arc cutting, or induction heating operations.

**ENDUSE can cause ENDHEATING**



- \* Allow cooling period.
- \* Reduce output or reduce duty cycle before starting to heat again.
- \* Follow rated duty cycle.



**STATIC (ESD) can damage PC boards**

- \* Put on grounded wrist strap BEFORE handling boards or parts.
- \* Use proper static-proof bags and boxes to store, move, or ship PC boards.

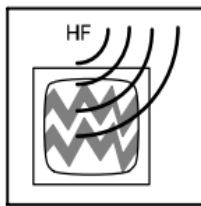

**H.F. RADIATION can cause interference**

- \* High-frequency (H.F.) can interfere with radio navigation, safety services, computers, and communications equipment.
- \* Have only qualified person familiar with electronic equipment perform this installation.
- \* The user is responsible for having a qualified electrician promptly correct any interference problem resulting from the installation.
- \* If notified by the FCC about interference, stop using the equipment at once.
- \* Have the installation regularly checked and maintained.
- \* Keep high-frequency source doors and panels tightly shut.

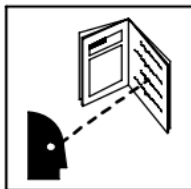

**READ INSTRUCTIONS.**

- \* Read Owner's Manual before using or servicing unit.
- \* Use only genuine replacement parts from the manufacturer.

## 1.4 Definition

### 1.4.1 Warning label Definitions

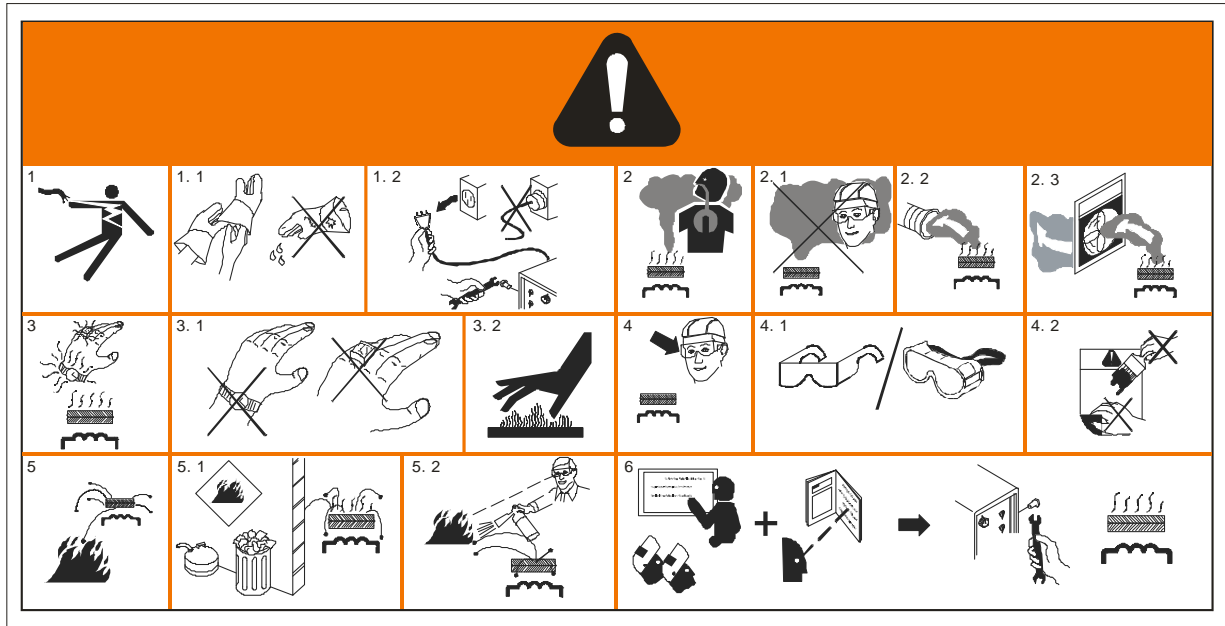

Warning! Watch Out! There are possible hazards as shown by the symbols.

1 Electric shock from wiring can kill.

1.1 Wear dry insulating gloves. Do not wear wet or damaged gloves.

1.2 Disconnect input plug or power before working on machine.

2 Breathing heating fumes can be hazardous to your health. Read Material Safety Data Sheets (MSDS) and manufacturer's instructions for material used.

2.1 Keep your head out of the fumes.

2.2 Use forced ventilation or local exhaust to remove the fumes.

2.3 Use ventilating fan to remove fumes.

3 Induction heating can cause injury or burns from hot items such as rings, watches, or parts.

3.1 Do not wear metal jewelry and other metal personal items such as rings and watches during operation.

3.2 Do not touch hot parts or hot head/coil.

4 Always wear safety glass or goggles during and around heating operations to prevent possible injury.

4.1 Wear either safety glasses or full goggles depending on type of operation and nearby processes.

4.2 Do not remove or paint over (cover) the label.

5 Induction heating sparks can cause fire. Do not overheat parts and adhesives.

5.1 Keep flammables away from heating operation. Do not heat near flammables.

5.2 Heating sparks can cause fires. Have a fire extinguisher nearby and have a watchperson ready to use it.

6 Become trained and read the before working on the machine or heating.

## 2. Safety Instructions and Maintenance

### 2.1 Safety Instructions

As the equipment working with 380 - 480V three - phase alternating voltage, the line voltage inside and outside is very high, when the equipment is running, any part of your body can not be close to the input and output terminals of the device. Though the induction heating equipment is not under work, the input and output terminals are still with dangerous voltage. Disconnecting power supply is a must if you need to check inside or maintenance. For purposes of safety, you must ensure the equipment without voltage several minutes after power off before unpacking maintenance.

### 2.2 Routine Maintenance



Disconnect power before maintaining

In order to ensure the induction heating power normal running and extend its life, regular maintenance is a must. Content of the maintenance is in the following table.

item	Content
temperature/humidity	ensure the ambient temperature -20°C ~ +50°C, relative humidity:20% ~ 90%
Oil mist and dust	ensure no oil mist, dust and condensation in the equipment. no corrosive gas and liquid in the storage ambient
Induction heating equipment	check it whether abnormal hot or vibrate
cooling liquid	check if cooling liquid is in accordance with requested (deionized purified water, PH 7.0~9.0)
Input power	ensure the input power voltage and frequency within the permit scope
coil	check the coil whether normal, it will show no oil mist, dust and condensation if it is not yellow

**table2-1 maintenance items**

In consideration of the running equipment easily to absorb dust, especial for the fan module, users should try to avoid the dust overstock which will affect the heat sink leading to any bad effects result from too high inside temperature. In order to extend the life of equipment, we suggest regular dedusting for the fan and radiator, at least one time within two months; regular dedusting for the equipment inside, at least one time within a year.

**Notice:** Ensure the power off before dedusting. Dedust with cloth and dry brush softly without water in case of damaging the components or even the complete set. While dedusting, ensuring the related plug-ins in good contact, avoid them losing in case of affecting the equipment running.

### 3.Type and Specification

#### 3.1 Unpacking Inspection

Unpack, take out the induction heating machine, please check the below items:

- ◆ensure no damage after transportation (Visual inspection whether there is damage or gap)
- ◆ensure package with manual
- ◆check the nameplate and confirm your order (the nameplate is on the right side of the equipment)
- ◆Any damage, please contact with our local dealers or our company.

#### 3.2 Specification

Type	Model	Version No.	Input	Output	cooling system	N.W	IP
Split - type	CR210C-030B-14TW	1	Power: 30KVA Voltage: 3-phase/400V(±20%) Frequency: 50-60Hz Current: 36-54A	Power: 24kW duty cycle: 100% Frequency: 10-40KHz	water pressure: 4~6 bar, flow rate: ≥35L/min, water quality: PH7.0-9.0 Cooling power: ≥21.5KW	33.5 kg	IP54
	CR210C-060B-14TW	1	Power: 60KVA Voltage: 3-phase/400V(±20%) Frequency: 50-60Hz Current: 72-108A	Power: 48kW duty cycle: 100% Frequency: 10-40KHz	water pressure: 4~6bar, flow rate: ≥75L/min, water quality: PH7.0-9.0 Cooling power: ≥45KW	33.5 kg	IP54
All- in- one Type	CR210C-030E-14TW	1	Power: 30KVA Voltage: 3-phase/400V(±5%) Frequency: 50Hz Current: 36-54A	Power: 24kW duty cycle: 30KVA=100% Frequency: 10-40KHz	water pressure: 4.6bar, flow rate: 100L/min, water quality: PH7.0-9.0 Cooling power: 21.5KW	400 kg	IP23
	CR210C-060E-14TW	1	Power: 60KVA Voltage: 3-phase/400V(±5%) Frequency: 50Hz Current: 72-108A	Power: 48kW duty cycle: >40KVA=50% ≤40KVA=100% Frequency: 10-40KHz	water pressure: 4.6bar, flow rate: 100L/min, water quality: PH7.0-9.0 Cooling power: 21.5KW	400 kg	IP23

#### 3.3 Commissioning before Starting

- (1) Check the input terminals R、S、T、PE and output terminals L1&L2 whether the connections are correct and screws are tight before power on.
- (2) ensure the equipment reliable grounding.
- (3) Power on, LCD will display set screen.
- (4) Check whether there is abnormal sound or other equipment failures, if so, immediately cut off the input power supply.
- (5) Turn power switch on, **system set screen start command** as **keyboard start** command, then set output Current as minimum value (such as 10A), no load running (press RUN to run), observe it whether normal.
- (6) After normally no-load running, stop it and cut off the power, then restart running with load.

## 4. Installation and Wiring

### 4.1 Installation Condition and Dismantle Cautions

For fans effective operation and radiating, keep enough space near the wind inlet and outlet, locate the equipment where ventilate and waterproof.



**Induction heating machine should run with anti-flaming material, away from heat source and flammable objects in case of fire disaster.**

### 4.2 Equipment Wiring Notices

- (1) Ensure input power switch off before wiring.
- (2) Input power line must be permanently connected, equipment reliable grounding.
- (3) The ground terminal of the equipment must be reliable grounding or it could cause a electric shock and fire hazard.
- (4) Do not connect the input power line to the output terminals L1, L2 or it could damage the induction heating equipment.
- (5) Do not touch the power input terminals R、S、T、PE; output terminals L1, L2, meanwhile do not connect L1, L2 to the shell or short connect with line.

### 4.3 Equipment Appearance and Wiring

#### 4.3.1 Split-type system wiring diagram

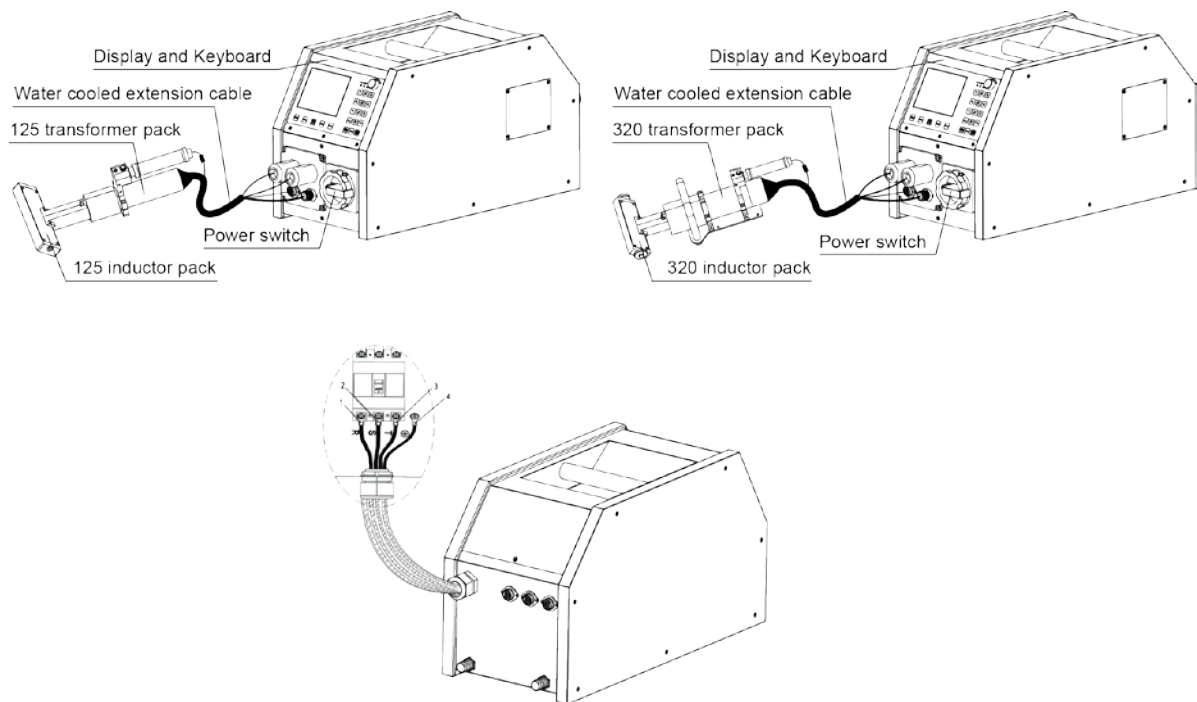

**Figure 4-3-1 wiring diagram of electricity input**

**4.3.2 Split-type requires chiller connection, see below schematic diagram**

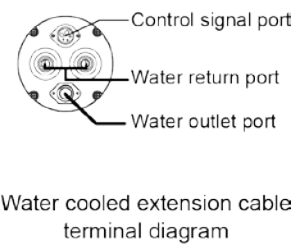
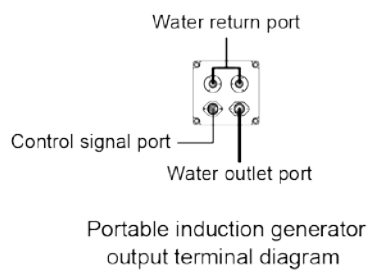
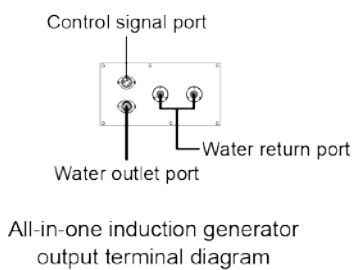
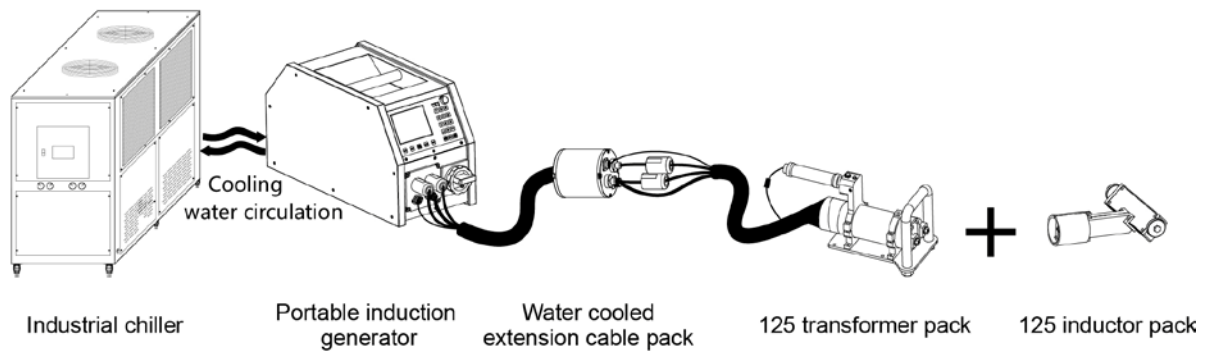
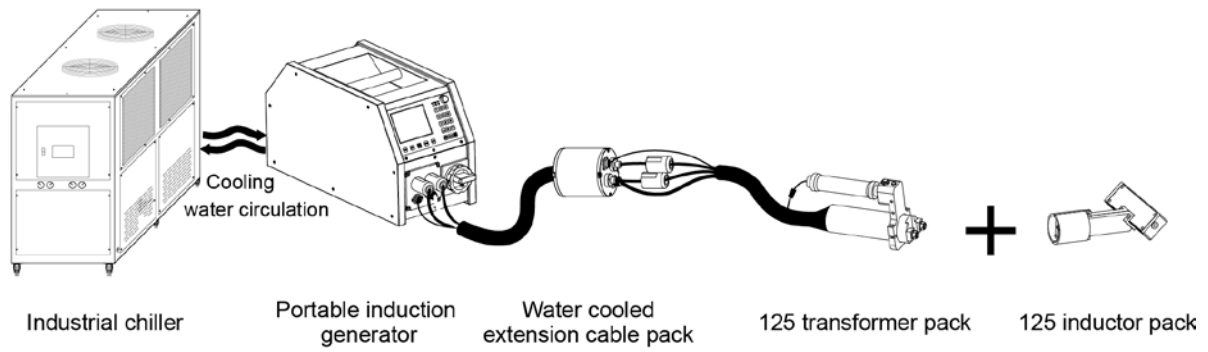
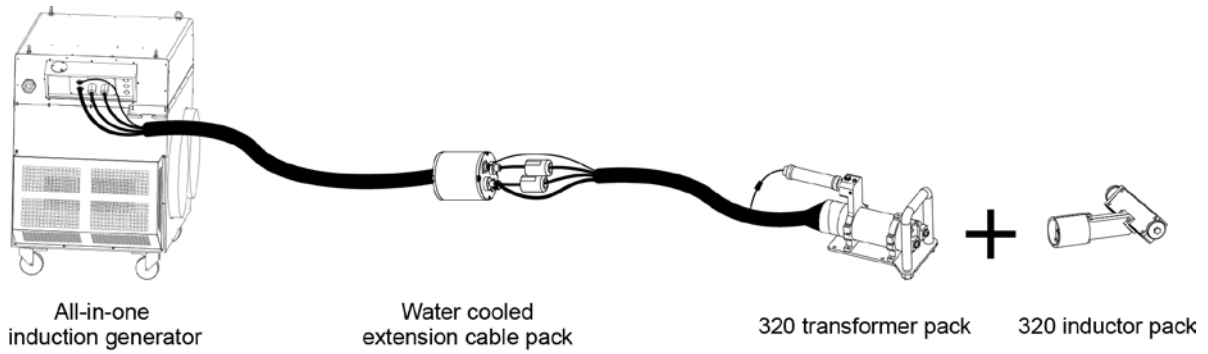
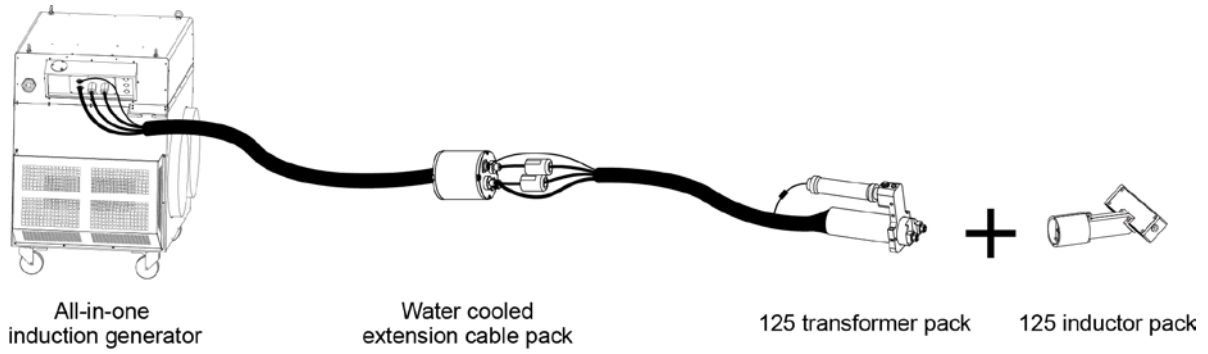

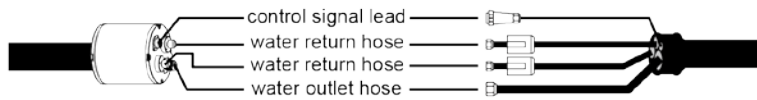

Water cooled extension cable & transformer connection diagram

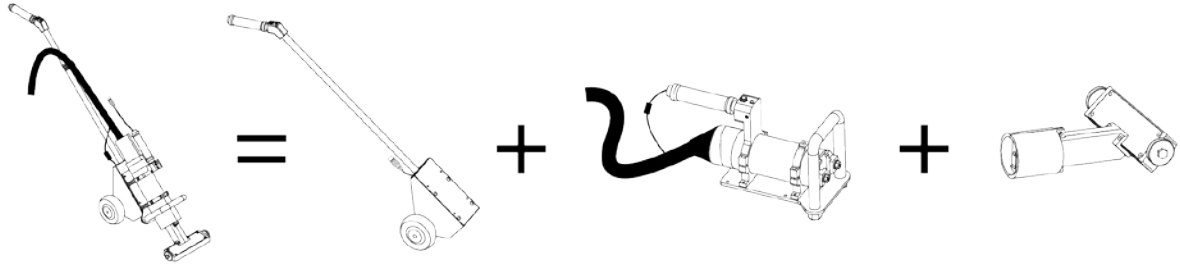
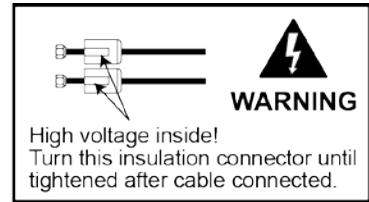

Complete coating removal trolley    Handheld trolley pack    320 transformer pack    320 inductor pack

**Figure 4-3-2-1 wiring diagram**

**4.3.3 Wiring diagram of external control port:**

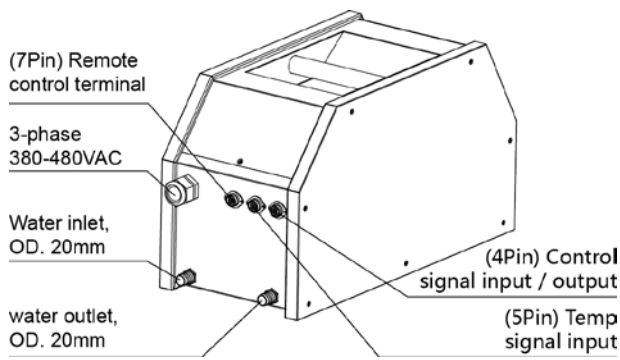

4pin definition of remote control connector

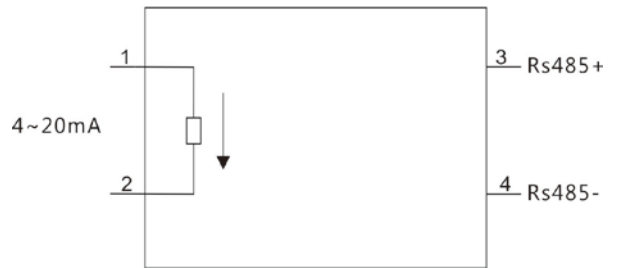

7pin definition of remote control connector

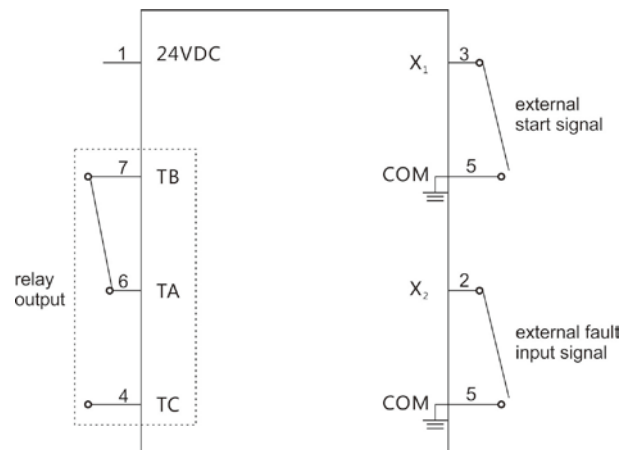
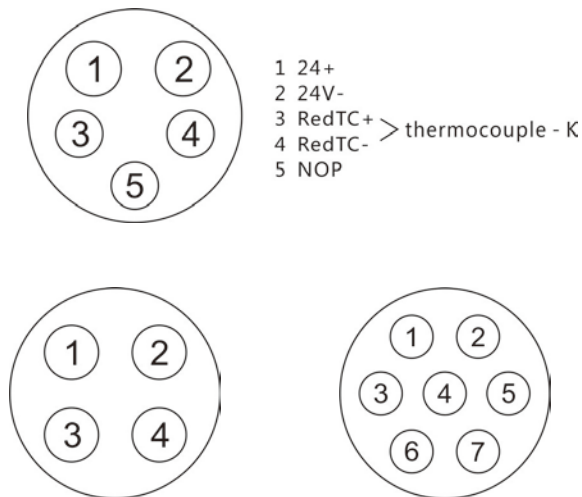

**Figure 4-3-3 wiring diagram of external control port**



*Check input voltage. This unit supports 380~480VAC, 3-phase, 50~60Hz input. Check nameplate on the unit for rated value, see if input voltage adapts.*

**Marks for input power connection parts**

- 1: red wire to terminal R**
- 2: black wire to terminal S**
- 3: blue wire to terminal T**
- 4: yellow wire to ground terminal PE**

Pass the wire through cable fixed head and tighten the screw.

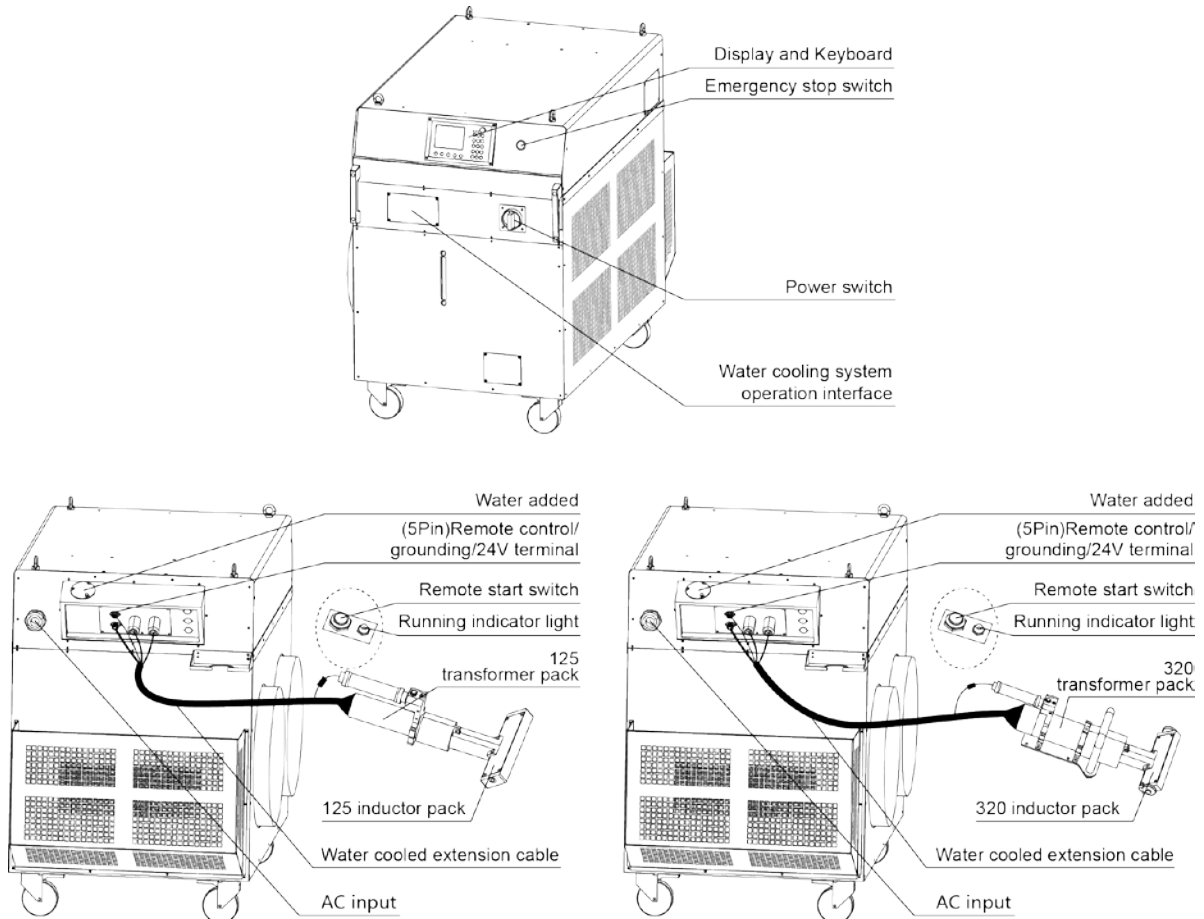
**4.3.4 All-in-one type system interface description**

**Figure 4-3-4 All-in-one type interface diagram**



Wiring should conform with national and local regulation - only the qualified can conduct the wiring.



Disconnect or turn off the power before connecting the input wire.



*Check input voltage. This unit supports 380VAC, 3-phase, 50/60Hz input power.*

**Check nameplate on the unit for rated value, see if the input power adapts.**

**Marks for input power connection part**







Connect input wire to terminal R, S, T, and tighten the screw.

**Marks for cutting off input power.**

OFF: disconnect equipment

ON: connect equipment

## 4.3.5 Coating removal inductor parameters

Picture	Size parameters	Model	N.W	Matched model
	202mm(L)*55mm(W)	CR240-125-AA	1.0kg	CR210C-030B-14TW CR210C-030E-14TW
	202mm(L)*65mm(W)	CR240-320-AA	2.0kg	CR210C-060B-14TW CR210C-060E-14TW
	Standard cable 5M	CR-125-24-5T	7.0kg	CR210C-030B-14TW CR210C-030E-14TW
	Standard cable 5M	CR-320-28-5T	12.0kg	CR210C-060B-14TW CR210C-060E-14TW
	Standard cable 20M, custom 25/30M available	CR140-020-JF	25.0kg	All model
	Height of handle above ground: 710mm	CR250-320-AA	4.0kg	CR210C-060B-14TW CR210C-060E-14TW

**4.3.6 Product structure and dimension installation**

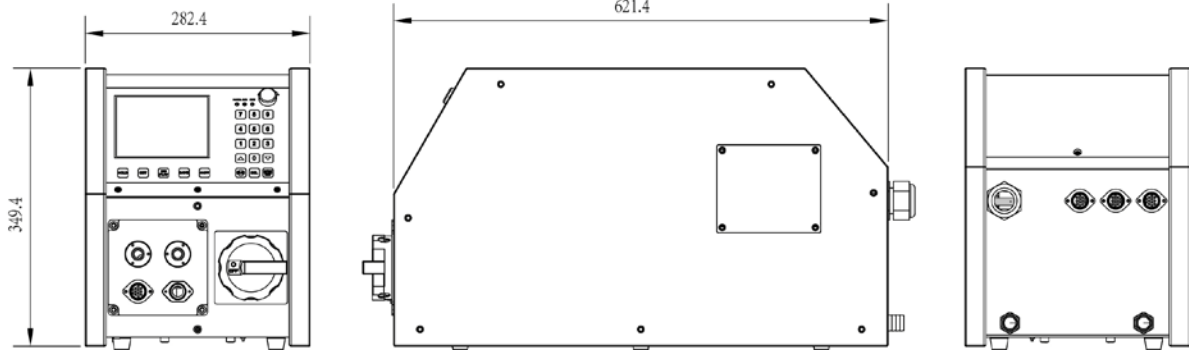

**CR210C-030B/060B-14TW**

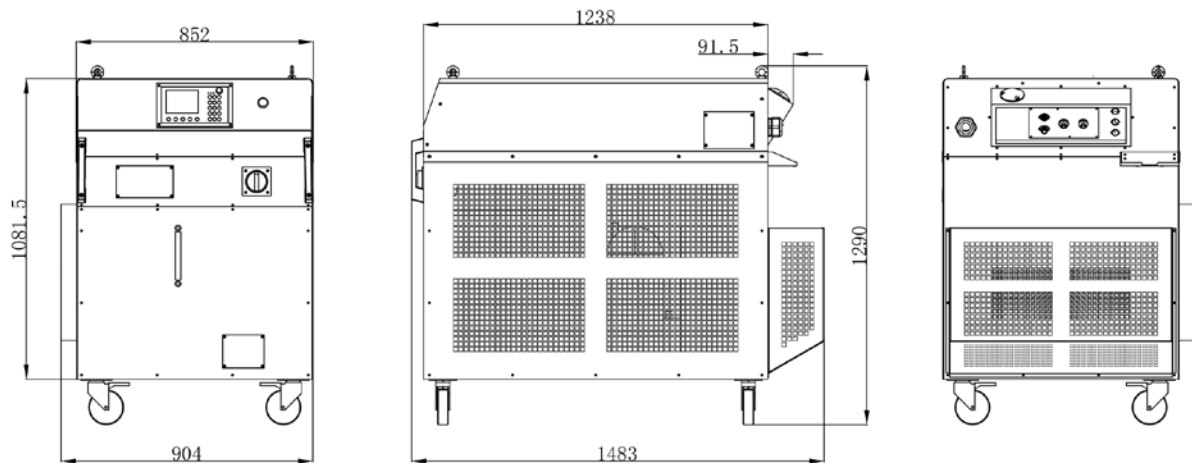

**CR210C-030E/060E-14TW**

## 5. Display and Operation Control

### 5.1 Safety Equipment

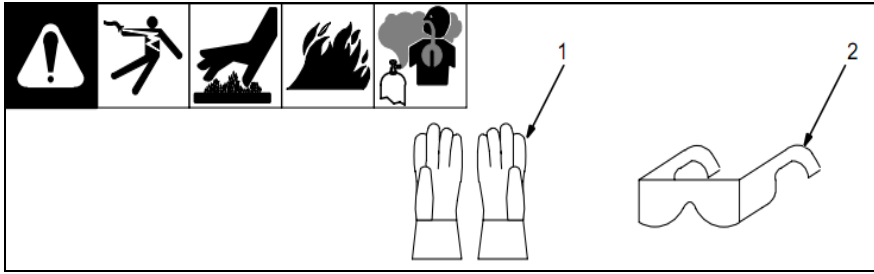

Wearing the following during operation:

1:dry, insulating gloves

2:safety glasses with side shields

Do not wear rings or watches during operations.

### 5.2 LCD Keyboard Instructions

Equipment display and operation mainly on the LCD and keyboard.

Following is the diagram and equipment display screen.

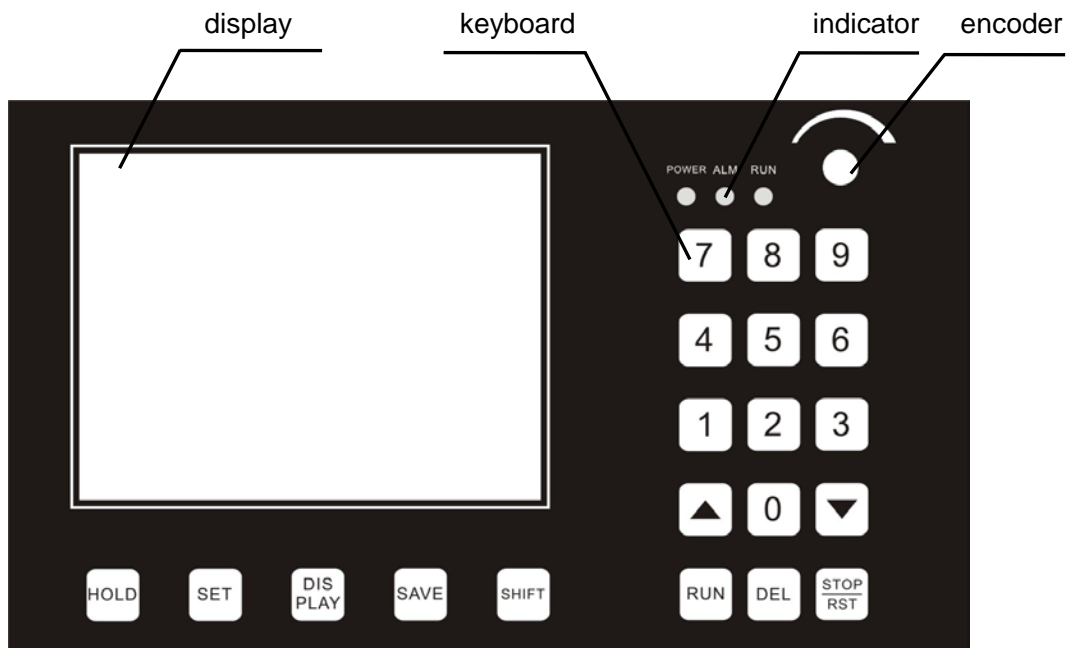













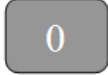

Chart 5-1 keyboard and LCD display diagram

Button function instructions

signal	function	instruction
	Shift Button	<p><b>System set</b> screen and <b>control mode set</b> screen cursor location;</p> <p><b>Basic parameters set screen</b> and <b>fault message screen</b> backtrack, go back to the previous menu</p>

	Hold Button	Other interface besides <b>faults alarm</b> interface and <b>code check</b> interface, Hold function when running, skip to <b>hold mode</b> . Then RUN indicator, Green (blue) light flashing
	Run	On the keyboard operation mode, press the button to start running RUN indicator green (blue) light on
	Stop/Reset	On the keyboard operation mode, press the button to stop running; After downtime, reset in case of fault RUN indicator light off
	Increase/Up	Data or parameter code add-
	Decrease/Down	Data or parameter code reduce-
	Encoder	Add or reduce output power values when operation
	Control Mode Parameter Set Button	Skip to <b>control mode set</b> screen, set relevant parameters
	Control Mode running Status Display Button	Skip to <b>running status</b> screen, monitor running mode status
	Parameters Save Button	Save parameters, all set parameters must be saved before effective
	System Set Screen Shortcut Button	SAVE+SET press both buttons simultaneously to skip to <b>System set</b> screen, Set temperature unit, control mode, start order, output Current
	Monitor Parameter Screen Shortcut Button	SAVE+DISPLAY press both buttons simultaneously to skip to <b>monitor parameter</b> screen, check output power, Current, frequency, transmitter temperature
	Basic Parameter Screen Shortcut Button	SAVE+SHIFT press both buttons simultaneously to skip to basic parameter screen, set parameter initialization, frequency range, running limitation time and so on
	Digit 0	Digit code input











	Digit 1	
	Digit 2	
	Digit 3	
	Digit 4	
	Digit 5	
	Digit 6	
	Digit 7	
	Digit 8	
	Digit 9	
	Delete	Delete digit values

chart 5-1 button function

### 5.3 Indicator and Display Mode

#### (1) indicator instructions

Pattern		Function instruction
Status Indicator	POWER	Power indicator, light red when power on
	RUN	light green (blue) when running, running indicate; green (blue) light flashing when device with hold status, hold status indicate
	Alarm	Alarm indicator, light yellow when equipment with fault or alarm

#### (2) display mode

Basic parameter	Basic parameter code display:PX.XX
Monitoring Parameter	Monitoring parameter code display:D-XX
Fault Display	Fault code display:E-XX
Alarm Display	Alarm code display: A-XX

Latest fault code and then power, Current and other values

Saved in the monitoring parameter D-22 ~ D-31, check the monitoring parameter D-22 ~ D-31 with the latest, second, third.....fault code and some other fault information.

Check the basic parameter PX.XX specification refer to 7.1 basic parameter

Check the basic parameter D.XX specification refer to 7.2 monitoring parameter

Check the basic parameter E.XX and A-XX specification refer to 8.1 fault and fault Parameter.





## 5.4 Parameter Screen Display and Set

### 5.4.1 System Set Screen

Press set button  and save button  and popup system set screen, as the below:

System Set Screen	
Degree Units....:	°C
Range.....:	±10°C
Language.....:	English
Curve Number..:	1
Control Mode...:	Temperature
Start Command.:	Keyboard
Input Power.....:	40.0KW
Output Current..:	233.0A

Alter Setting:

- Press shift button , move the cursor to the parameters to be altered
- Press increase button  or decrease button  to choose the value to be set (except the time value, only digit can be input in the time value)
- Value parameters such as power, Current, temperature difference value can be input with numeric button (0 ~ 9), use delete button  to delete
- Press save button , values will be saved

#### Optional Items:

Degree Unit: °C/°F	【Factory Set °C】
Range: ±1 ~ 55°C (±2 ~ 99°F)	【Factory Set 10°C】
Language: English	【Factory set English】
Curve Number: 1/2/3	【Factory Set 1】
Control Mode: temperature/power	【Factory Set temperature】
Start Command: remote/keyboard	【Factory Set keyboard】
Input Power: 0.0 ~ Rated Input Power	【Factory Set Rated Input Power】
Output Current: 1.0 ~ Rated Output Current	【Factory Set Rated Output Current】

 *Temperature difference range is to adjust temperature when set temperature and feedback temperature difference value deviate between positive and negative.*  
*All of the system parameters are global parameter, any system parameter to be altered will apply to all the programme.*

when set input power, **【input power】** input value less than the set **【power】** value in the **constant power set screen** or **power VS time set screen**, then press save



Button  , it display as the below:

Never set system set screen **【input power】** value  
Less than the set **【power】** value in the **constant power set screen**  
or **power VS time set screen**

## 5.4.2 Control Mode Set Screen

Allow users to set control procedure for specific heating procedure.  
Optional control procedure include temperature and power

### 5.4.2.1 Temperature Control

Temperature control heating procedure is based on the thermocouple feedback temperature. Temperature control mode include four different procedures as the following: **Constant Temp, Back-out, Heat Treatment (HT)** and **user-defined mode**.



Press  and  button to popup the system set screen. Set

**【control mode】** as **【temperature】** , press save button  to save, then press



 button to skip to temperature control set screen.

When skip to temperature control set screen, LCD will display as the followings:

Temperature Control Mode Set Interface

> Constant Temp  
Bake-Out  
HT  
Custom



Press shift button  to move the cursor to choose mode;



Use  button to save chosen mode and skip to the set interface corresponding to the chosen temperature control mode.





### 5.4.2.1.1 Constant Temp

**Constant Temp** procedure is a simply method of heating the material to some temperature and keep constant for a time.

When the chosen temperature control mode in the temperature control mode set interface is Constant Temp, LCD will display as the followings:

Constant Temp Set Screen	
Mode .....	> Constant Temp
Control TC..:	1
Temperature :	150°C
Soak Time...:	01:00:00

Alter Set:

- Press shift button  to move the cursor to the parameters to be altered
- Press increase button  or decrease button  to choose designated value (except time value, only input digit with time value)
- Numerical parameters, such as temperature, power, time, input the values with digit button (0 ~ 9), use delete button  to delete.
- Press save button , values will be saved

#### optional Items:

Mode: Constant Temp	
Control TC: 1, 1, 2	【Factory Set 1】
Temperature: 0 ~ 1300°C (32-2372°F)	【Factory Set 150°C】
Soak time: 00:00:01 ~ 99:59:59	【Factory Set 00:00:00】

 TC1 must be controlling thermocouples and masterly controlling temperature.

*CR2000-005/010B-14TF1 support two thermocouple input*





### 5.4.2.1.2 Bake-Out

**Bake-out mode** is heating workpieces at a quick increase rate to a temperature and hold it for a while, then cool down to the specified temperature.

When the chosen temperature control mode in the temperature control mode set interface is bake-out, LCD will display as the followings:

Bake-out Set Screen	
Mode.....:	> bake-out
Control TC.....:	1
Soak Temperature :	600°C
Soak Time.....:	02:00:00
Cool Temperature :	200°C
Cool Rate.....:	80°C/hr

Alter Set:

- Press shift button  to move the cursor to the parameters to be altered
- Press increase button  or decrease button  to choose Designated value (except time value, only input digit with time value)
- Numerical parameters, such as temperature, power, time, input the values with digit button (0 ~ 9) , use delete button  to delete.
- Press save button , values will be saved

#### Optional Items:

Mode: **bake-out**

Control TC:1, 1, 2

【Factory Set 1】

Soak temperature:0 ~ 1300°C (32-2372°F)

【Factory Set 600°C】

Soak time: 00:00:00 ~ 99:59:59

【Factory Set 02:00:00】

Cool temperature: 0 ~ 1300°C (32-2372°F)

【Factory Set 200°C】

Cool rate: 1 ~ 6000°C/hr (34 -10832°F/hr)

【Factory Set 80°C/hr】

 TC1 must be controlling thermocouples and masterly controlling temperature.

*CR2000-005/010B-14TF1 support two thermocouple input*

#### 5.4.2.1.3 HT (Heat Treatment)

##### HT process:



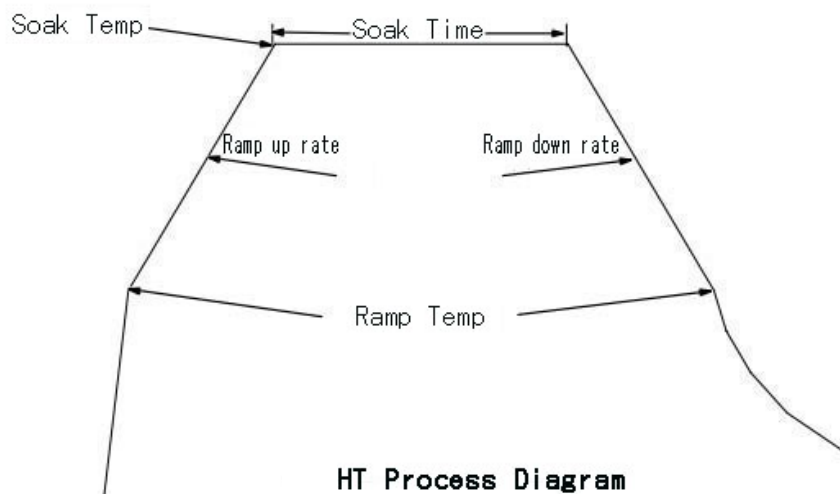

- (1) heat workpiece from ramp temperature to soak temperature at ramp up rate
- (2) hold workpiece temperature at soak temperature point for a while (soak time).
- (3) cool down workpiece from hold temperature to ramp temperature at ramp down rate.



When the chosen temperature control mode in the temperature control mode set interface is HT, LCD will display as the followings:

HT Set Screen	
Mode.....:	> HT
Control TC.....:	1
Ramp Temp.....:	200°C
Ramp Rate.....:	80°C/hr
Soak Temp.....:	600°C
Soak Time.....:	02:00:00

Alter Set:

- Press shift button  to move the cursor to the parameters to be altered
- Press increase button  or decrease button  to choose designated value (except time value, only input digit with time value)
- Numerical parameters, such as temperature, power, time, input the values with digit button (0 ~ 9) , use delete button  to delete.
- Press save button , values will be saved

#### Optional Items:

Mode:: **HT**

Control TC: 1, 1, 2

**【Factory Set 1】**

Ramp temperature: 0 ~ 1300°C (32-2372°F)

**【Factory Set 200°C】**

Ramp rate: 1 ~ 6000°C/hr (34 -10832°F/hr)

**【Factory Set 80°C/hr】**

Soak temperature: 0 ~ 1300°C (32-2372°F)

**【Factory Set 600°C】**

Soak time: 00:00:00 ~ 99:59:59

**【Factory Set 02:00:00】**



TC1 must be controlling thermocouples and masterly controlling temperature.

*CR2000-005/010B-14TF1 support two thermocouple input*





#### 5.4.2.1.4 Custom

Users can define procedure or dissymmetry heat treatment procedure, with which the heating rate, cooling rate and temperature can be different.

When the chosen temperature control mode in the temperature control mode set interface is custom, LCD will display as the followings:

Custom Set Screen	
Mode.....:	> Custom
Curve Num...:	1
Segment.....:	1
Type .....	END
Control TC...:	1

Alter Set:

- Press shift button  to move the cursor to the parameters to be altered
- Press increase button  or decrease button  to choose designated value (except time value, only input digit with time value)
- Numerical parameters, such as temperature, power, time, input the values with digit button (0 ~ 9), use delete button  to delete.
- Press save button , values will be saved

**Optional Items:**Mode: **Custom**Curve Num.: 1 ~ 3 (curve no can not be set in this screen but can be in the **System set screen**)

Segment: 1 ~ 10	【Factory Set 1】
Type: <b>soak/ramp/step/end</b>	【Factory Set end】

◆ for **soak** type:

Soak temperature: 0 ~ 1300°C (32-2372°F)	【Factory Set 0°C】
Soak time: 00:00:00 ~ 99:59:59	【Factory Set 00:00:00】

◆ for **ramp** type:

Ramp temperature: 0 ~ 1300°C (32-2372°F)	【Factory Set 0°C】
Ramp rate: 1 ~ 6000°C/hr (34 -10832°F /hr)	【Factory Set 0°C/hr】

◆ for **step** function:

temperature: 0 ~ 1300°C (32-2372°F)	【Factory Set 0°C】
-------------------------------------	-------------------

◆ for **end** type:

Control TC: 1, 1, 2,	【Factory Set 1】
----------------------	-----------------

 TC1 must be controlling thermocouples and masterly controlling temperature  
*CR2000-005/010B-14TF1 support two thermocouple input*

Temperature controlling, ramp is calculated in °C/hr or °F /hr, programmable ramp minimum and maximum value is 0°C/hr (34°F /hr) and 6000°C/hr (10832°F /hr) .Minimum and maximum programmable temperature is 0°C (32°F) and 1300°C (2372°F) .Minimum and maximum soak time is 0 and 100 hours.user-defined function can set 3 curves at maximum, choose curve NO in the **system set screen**, each curve can set 10 segments at maximum, choose segment NO in the user-defined screen.When segment NO changed, it will display corresponding segment parameter information. End the programme indicate the completion of the cycle and the end of the output power.

user-defined segment controlling heating procedure:  
 type as **step** function:

```

Custom Set Screen
Mode.....: > Custom
Curve Num...: 1
Segment.....: 1
Type.....: Step
Temperature..: 200°C

```

Full power heating to 200°C

type as **ramp**:

```

Custom Set Screen
Mode.....: > Custom
Curve Num.....: 1
Segment.....: 2
Type.....: Ramp
Target Temperature: 600°C
Ramp Rate...: 600°C/hr

```

At 600°C/hr rate, controlling heating to 600°C.

type as **soak**:

```

Custom Set Screen
Mode.....: > Custom
Curve Num.....: 1
Segment.....: 3
Type.....: Soak
Soak Temperature.: 600°C
Soak Time.....: 01:00:00

```

600°C soak one hour

Type as **ramp**:

```

Custom Set Screen
Mode.....: > Custom
Curve Num...: 1
Segment.....: 4
Type.....: Ramp
Ramp Temperature: 400°C
Ramp Rate.....: 600°C/hr

```

At 600°C/hr rate, controlling cooling to 400°C.

Type as **end**:

```

Custom Set Screen
Mode.....: > Custom
Curve Num: 1
Segment....: 5
Type .....: END
Cotrol TC...: 1



```

End segment end heating circle

### 5.4.2.2 Power Control

Power control mode is a method with output power. Power control mode includes the following two different processes: constant power mode, power VS time mode.

Press set button  and save button , popup system set screen, set

**【Control Mode】** as **【Power】**, press save button  to save, then press set button , skip to power control mode set interface.

When skip to power control mode set interface, LCD will display as the followings:

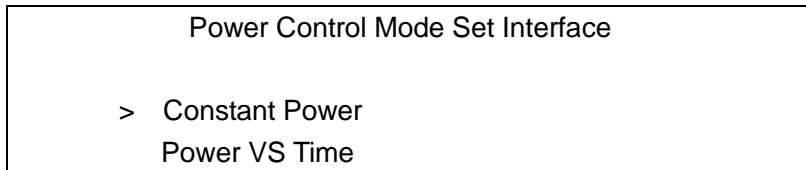

Press  to move the cursor to choose mode;

Press  to save chosen mode and skip to the set interface corresponding to the chosen power control mode.

#### 5.4.2.2.1 Constant Power

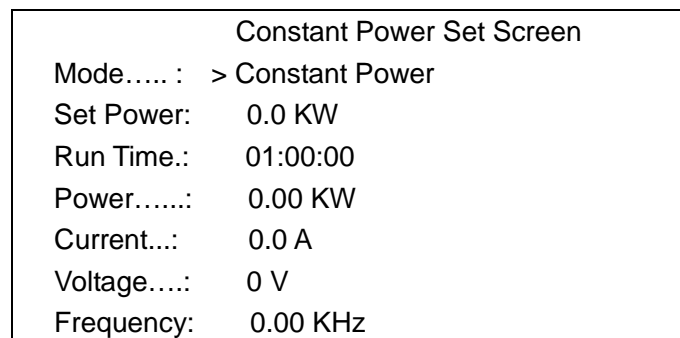

Constant power mode is running a certain time at a constant power (when running time is 00: 00:00 as infinite running mode)

When the chosen power control mode in the power control mode set interface is constant power, LCD will display as the followings:



Alter Set:

● Press shift button  to move the cursor to the parameters to be altered

● Press increase button  or decrease button  to choose designated value (except time value, only input digit with time value)



• Press save button , values will be saved

• Numerical parameters, such as temperature, power, time, input the values with digit



button (0 ~ 9) , use delete button  to delete.

**Optional Items:**

Mode: constant power

Set Power: 0 ~ output power set value in **system set**

**Screen**

**【factory set as 0 kW】**

Run Time: 00:00:00 ~ 99:59:59

**【factory set as 00:00:00】**

Last 4 parameters, power, Current, voltage, frequency as device running monitoring parameters.

**5.4.2.2.2 Power vs Time**

Power VS Time mode is based on the relationship ratio between time and power  
 When the chosen power control mode in the power control mode set interface is power VS time, LCD will display as the followings:



Power VS Time Set Screen	
Mode.....:	> Power vs Time
Curve Num.:	1
Segment....:	1
Type.....:	Power Soak
Power.....:	0.0 KW
Time.....:	01:00:00

Alter Set:



• Press shift button  to move the cursor to the parameters to be altered



• Press increase button  or decrease button  to choose designated value (except time value, only input digit with time value)

• Numerical parameters, such as temperature, power, time, input the values with digit



button (0 ~ 9) , use delete button  to delete.



• Press save button , values will be saved

**Optional Items:**

Mode: Power VS Time

Curve Num: 1 ~ 3 (curve no can not be set in this screen but can be in the **system set screen**) **【factory set as 1】**

Segment: 1 ~ 10

**【factory set as 1】**

type: **power soak/power ramp /end**

**【factory set as end】**

◆ for type as **power soak/power ramp**, only power and time can be set:

power: 0 ~ Set output power set value in **system set screen** **【factory set as 0 kW】**

time: 00:00:00 ~ 99:59:59

【factory set as 00:00:00】

**power control mode** can be set up to 3 curves, curve number in the **system set screen** selection, each curve can set 10 segments. When segment number changed, it will display corresponding segment parameter information.

for type as **end**, Indicates that the termination of the cycle of completion and output power.

### 5.4.3 Running Status Screen

With running status, users can monitor device running status during heating process. According to control mode (temperature or power), temperature mode (preheating, bake-out, PWHT or user-define) and power mode (constant power or power time), the display will show different screen.

With running status screen, just for monitoring but no optional or alterable parameters.

#### 5.4.3.1 Temperature Control Status Screen

Press running status display button , popup control mode running status screen, display as the followings:

##### (1) Constant Temp, Bake-out and HT running status screen

Run Status Screen	
Mode .....	Constant Tempt      TC1: 30.0
Target Temp.:	150°C                      TC2: OPEN
Countdown..:	01:00:00
Status.....:	Stopped

Mode display the programme mode (Constant Tempt, Bake-out, HT, or Custom). During operation, Target Temp display present operation target temperature, Countdown display remaining time, present status (Running, Hold, Stopped). TC1 ~ TC2 display thermocouple 1 ~ 2 temperature. The screen is hold for monitoring or present type (Soak, Step, ramp, end TC1 ~ TC2 display thermocouple 1 ~ 2 temperature. The screen is just for monitoring.

##### (2) user-defined running status screen

###### First Segment:Step

Run Status Screen	
Mode.....:	Custom                      TC1: 200.0
Target Temp:	200°C                      TC2: OPEN
Countdown....:	00:00:00
Type.....:	Step
Curve Num...:	1
Segment.....:	1

###### Second Segment:Ramp Up Temperature

Run Status Screen	
Mode.....:	Custom                      TC1: 200.0
Target Temp:	400 °C                      TC2: OPEN
Countdown..:	00:03:20

Type.....: Ramp
Curve Num.: 1
Segment.....: 2

**Third Segment:Soak**

Run Status Screen	
Mode.....: Custom	TC1: 400.0
Target Temp: 400 °C	TC2: OPEN
Countdown.: 00:05:00	TC3: OPEN
Type.....: Soak	
Curve Num.: 1	
Segment.....: 3	

**Fourth Segment:Ramp Down Temperature**

Run Status Screen	
Mode.....: Custom	TC1: 200.0
Target Temp: 200 °C	TC2: OPEN
Countdown.: 00:03:20	
Type.....: Ramp	
Curve Num: 1	
Segment.....: 4	

**Fifth Segment: End Segment, device stop running, none screen display**

**5.4.3.2 Power Control Status Screen**



Press running status display button  , popup control mode running status screen, it displays as the followings:

**(1) constant power running status screen**

Run Status Screen	
Mode .....: Constant Power	TC1: 30.0
Power.....: 0.00 KW	TC2: OPEN
Countdown: 01:00:00	
Status.....: Stopped	

Power display present actual output power, Countdown display thermal cycle remaining time, Status indicate present work status running or stop.TC1 ~ TC2 display thermocouple 1 ~ 2temperature, The screen is just for monitoring.

**(2) power VS time running status screen**

Run Status Screen	
Mode.....: Power vs Time	TC1: 30.0
Curve Num.: 1	TC2: OPEN
Segment.....:1	
Type.....: End	
Power.....: 0.00 KW	
Countdown: 00:30:00	

Mode display present working mode, Curve Num indicate curve NO, Segment indicate present working segment NO, Power display present actual output power, Countdown display remaining time, Type display present segment type (Power\_Soak, Power\_ramp, End). TC1 ~ TC2 display thermocouple 1 ~ 2 temperature. The screen is just for Monitoring.

#### 5.4.4 Custom Segment Record Interface

In Custom Segment Record Interface, it is available for users to check Custom Mode set values in shutdown state or hold state and can choose needed segments to start running from chosen segment.

This interface can be just entered from running state interface of Custom Mode in shutdown or hold state.

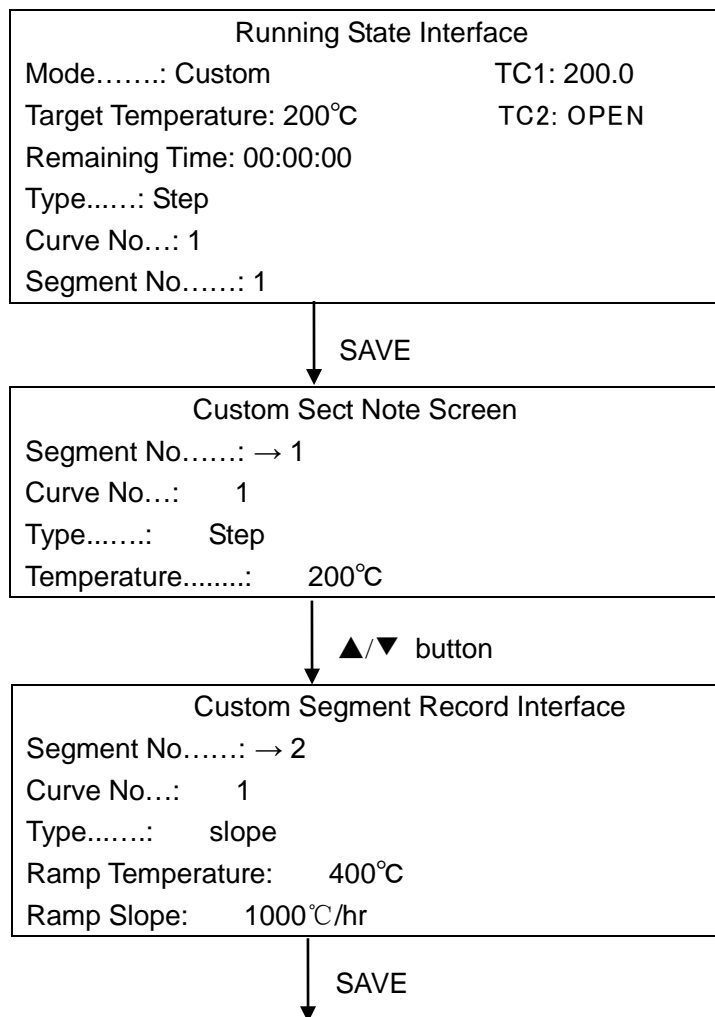

In Running State Interface of Custom Mode, press  to skip to Custom Segment Record Interface in shutdown or hold state, display as the below:



Running State Interface	
Mode.....: Custom	TC1: 200.0
Target Temperature: 400 °C	TC2: OPEN
Remaining Time: 00:00:00	
Type.....: slope	
Curve No....: 1	
Segment No.....: 2	

In Custom Segment Record Interface, each segment value can be checked by up and down button, press hold button to choose run initial segment and return to custom run interface. In this interface, segment value can just be checked but modified.



#### 5.4.5 Monitoring Parameters, Fault Code Record Display

Simultaneously press save button  + running status display button , popup **monitoring parameter screen**, as the chart below:

Monitoring screen	
▶D-00 Input Power:	0.00 KW
D-01 Input Voltage:	0 V
D-02 Input Current:	0.0 A
D-03 Output Frequency:	0.00 KHz
D-04 Total Output Current:	0.0 A
D-05 First Output Current:	0.0 A

**Chart 5-3 monitoring screen diagram**

monitoring parameter display screen:

On the monitoring parameter screen, use UP  and DOWN  button to move the cursor up and down, 32 monitoring Parameters in total, for more monitoring parameters, refer to 7.3 monitoring Parameter. The specific values can't be modified but check.

#### fault code display screen:

Skip to monitoring parameter screen, when cursor ▶ location to **D-22 ~ D-31** (fault



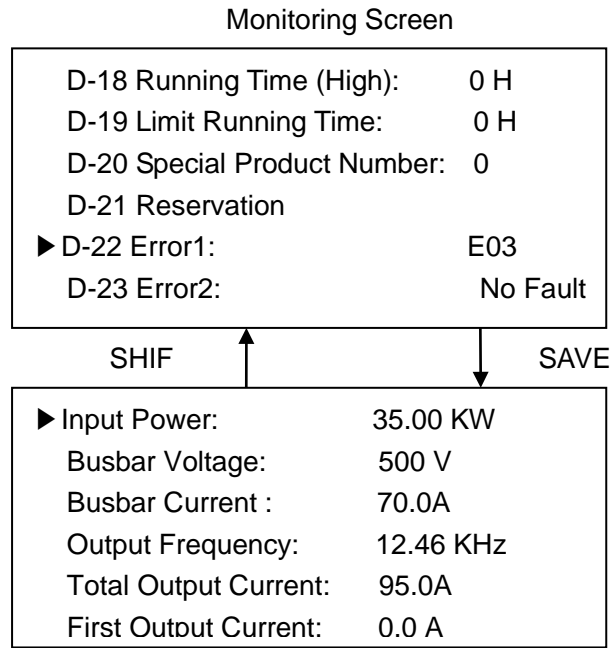

code parameter), if the parameter display with fault (fault as: E03) press  button to **fault message screen**, none faults, then can not skip to **fault message Screen** (no fault display: No Fault), as the diagram below:

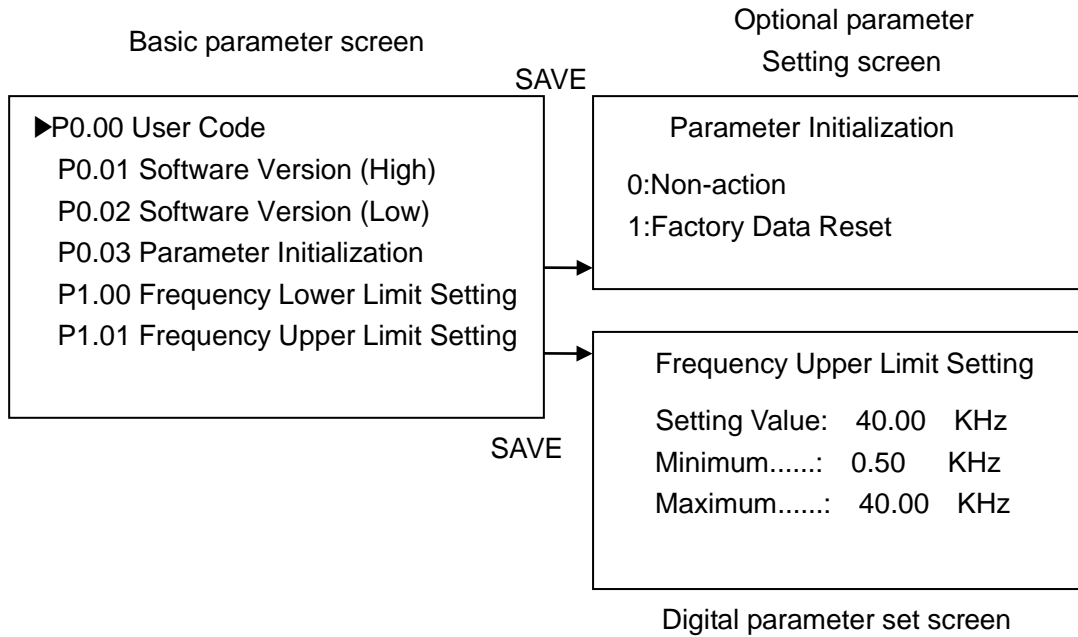

**Chart 5-4 fault message screen diagram**

### 5.4.6 Basic Parameters Display

**basic parameter display screen:**

Simultaneously press save button  + shift button , popup code check interface, code check correction then skip to **basic parameter screen**, in basic parameter screen can use  /  move cursor▶up and down, for more basic parameters, please check 7.1 basic parameter table.as the following diagram:





**Chart 5-5 basic parameter screen diagram**

Basic parameter set screen:

(1) optional parameter set screen:

Go to optional parameter set screen, press  button, →**optional cursor**

occurs before the below optional item, indicate can use  /  button to

move cursor, choose needed item (as the below:Manual PID Control), Press 



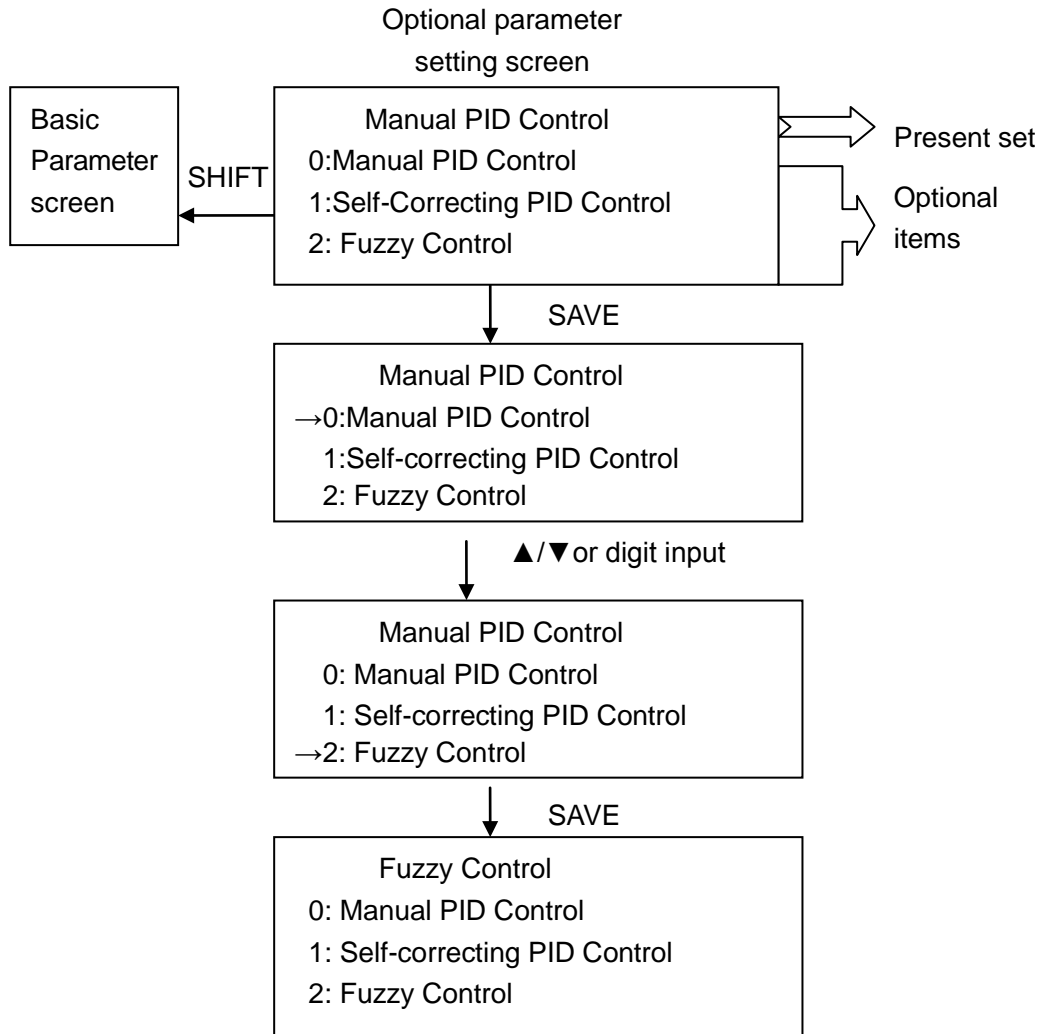

to confirm, **optional cursor**→disappear and the present set item site display as a latest set item (as the below:Fuzzy Control), set is finished.

As the following diagram:

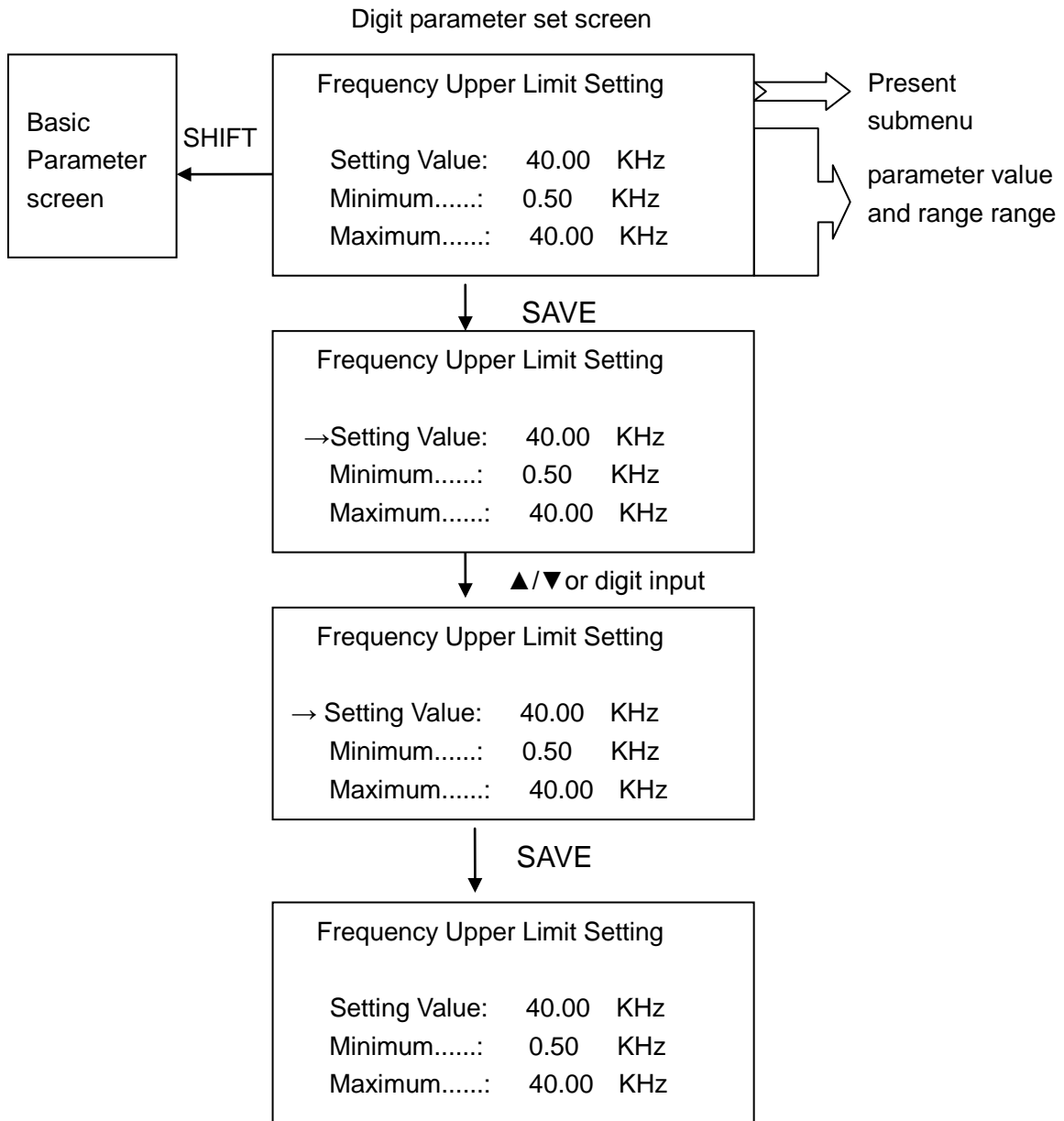

**Chart 5-6 optional parameter set screen**

(2) digit parameter set screen:

Go to digit parameter set screen, press  , → **optional cursor** Occurs in front of the below optional item, indicate can use  /  button or fast input needed set value (as the below: 40.00KHz), Press  to confirm, **optional cursor**→disappear, then set is inished, the maximum value and minimum value in the Chart 5-7 as input value range, they can not be modified.use  to go back to basic parameter sub menu Screen.

As the following diagram:



**Chart 5-7 digit parameter set screen diagram**

Note: some parameter modify with limitation, such as curve heat power and time, can not be modified under running but stop. More detailed information, refer to the sign instruction in the end of the basic parameter table.

### 5.4.7 Fault Alarm Screen Display

fault alarm screen:

Fault alarm screen, display present fault code and the fault information, as the following diagram:

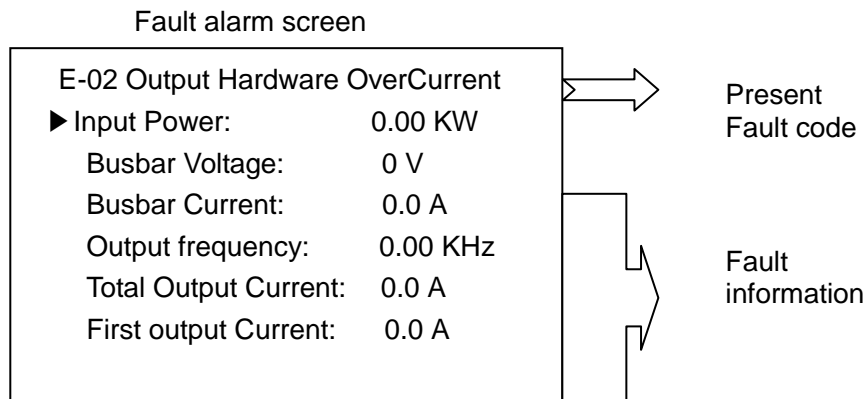

**Chart 5-8 Fault alarm screen**

### 5.5 Hold Button (constant temperature/constant power) function

Other interface besides faults alarm interface and code check interface, can hold the

present status during running. With running status, press hold button , it will start hold function, then RUN indicator green (blue) light flashing. On hold mode, programme

parameters can be altered. Press hold button , it will cancel hold function, RUN indicator green (blue) flashing disappears. On the hold mode, if some relevant parameters be altered, the programme will continue heating with the latest altered parameters.

### 5.6 Code Set and Check

#### Code set

From code parameter (P0.00, P3.02) to parameter set screen, press

  or fast digit input code, press  then finish the code set and save

It. As the following diagram:

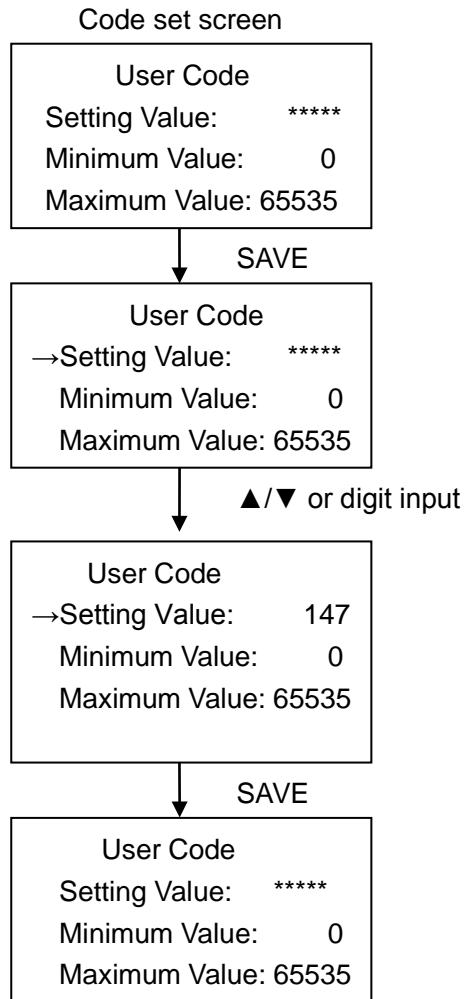

**Chart 5-9 code set screen diagram**

① user code (P0.00) function

User code factory value: 2014. After set user code, any tunable parameter can not be checked and modified.

② running limitation code (P3.02)

After set running limitation code, running limitation set (P3.03) parameter and running limitation time set (P3.04) parameter can not be modified.

Code check

From other screens to basic parameter series screens, a code check screen will

pop out if it has user code, press   or input the code value

digit, press  to confirm code input check. It will display "code is correct" if input correctly or it will display "code is wrong" then back to the code check screen. as the following diagram:

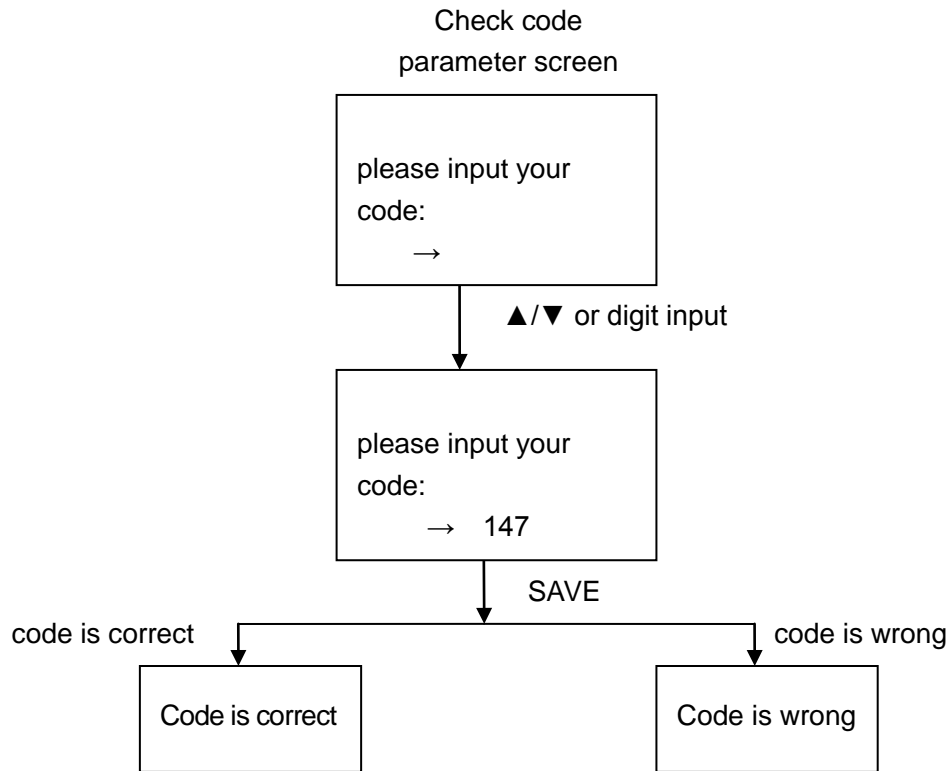

**Chart 5-10 user code check diagram**

**Note:** If you forget the code, please contact with the manufacturer.

## 6. Function Instruction

### 6.1 Parameters Initialization Function (P0.03)

Set parameters initialization (P0.03) as non action, then parameters can not be initialized.  
Set parameters initialization (P0.03) as parameters P initialization, then parameters P can be initialized, parameters reset to Factory Defaults.

### 6.2 Temperature Control Option Parameters (P2.03/P2.04)

#### (1) system parameters self-test choice (parameter P2.04)

**None-action:**

Set system parameters self-test choice (P2.04) as non-action, then system parameters do not self-test.

**System parameters test:**

Set system parameters self-test choice (P2.04) as system parameters test, then the system will automatic test system parameters according to the load condition, make temperature control with optimal state.

#### (2) temperature adjustment method choice (parameter P2.03)

**Manually set PID control:**

Set temperature adjustment method choice (P2.03) as manually set PID control, then set the PID parameters according to the actual conditions (proportion gain high and low digit number (F2.07 ~ F2.08)、integral time (F2.09)、differential time (F2.10)) value.

**Self-Correcting PID control:**

Set temperature control mode choice (P2.03) as self-correcting PID control, then machine will automatically self-correct parameters, on condition that PID actual parameters must pass system parameter self-inspect choice (P2.04) set as system parameters inspect acquire.

**vague control:**

Set temperature control mode choice (P2.03) as vague control, then machine inner regulation control load temperature.

When temperature overshoot value do not meet the need, appropriately increase parameter (P2.05) value, but may affect the temperature rise speed. When stable deviation temperature do not meet the need, appropriately decrease parameter (P2.06) value.

**6.3 Language Choice (P3.05)**

Set language choice (P3.05) as English, then all screens display in English.

Set language choice (P3.05) as Chinese, then all screen display in Chinese.

**6.4 TC type selection (P3.06)**

Set TC type (P3.06) as K, thermocouple TC1~TC2 input type will be selected as K type thermocouple detection.

Set TC type (P3.06) as Infrared, thermocouple TC1~TC2 input type will be selected as infrared detection.

**7. Parameter table****7.1 Basic Parameter Table**

CR210C Basic Parameter Table					
Label Instructions: “x” indicate the parameter can not be modified under running “◆” indicate the parameter value is actual value, can not be modified “○” indicate the parameter set value can be modified under running “—” indicate the parameter can not be modified as a reservation “◇” manufacturer parameter, only manufacturers modify, users are not permitted					
Function	Instruction	Set Scope	Unit	Factory Set Value	Modify
P0: System Parameter					
P0.00	User Code	0 ~ 65535	1	****	x
P0.01	Software Version (High)	0000 ~ FFFF	1	Machine type set	◆
P0.02	Software Version (Low)	0000 ~ FFFF	1	Machine type set	◆
P0.03	Parameter Initialization	0: Non-action 1: Factory Data Reset	1	0	x

P1:Basic Running Parameter					
P1.00	Frequency Lower Limit Setting	0.50KHz ~ 【P1.01】	0.01KHz	Machine type set	×
P1.01	Frequency Upper Limit Setting	【P1.00】 ~ 40.00KHz	0.01kHz	Machine type set	×
P1.02	Encoder Power Control Speed	1 ~ 300	1	30	○
P2:Control Parameter					
P2.00	The Switch OF E-24	0: Forbit, 1: Valid	1	1	○
P2.01	The Switch OF E-03	0: Forbit, 1: Valid	1	1	○
P2.02	Power Ramp Up Time [Constant Power Mode]	0.1~60.0S	0.1S	0.5S	○
P2.03	Temperature Control Mode	0:Manual PID Control 1:Self-Correcting PID Control 2: Fuzzy Control	1	2	×
P2.04	System Parameter Self- adjusting	0:Non-action 1:System Parameter Self-adjusting	1	0	×
P2.05	Input Quantization Factor	0.1 ~ 10.0	0.1	5.0	×
P2.06	Output Proportion Factor	0.0 ~ 6553.5	0.1	6.0	○
P2.07	Proportion Gain (High)	0 ~ 9999	1	0	○
P2.08	proportion Gain (Low)	0 ~ 99.99	0.01	50.00	○
P2.09	Integral Time	0.00S ~ 655.35S	0.01S	0.00S	○
P2.10	Differential Time	0.00S ~ 655.35S	0.01S	0.00S	○
P2.11	Sampling Cycle	0.01 ~ 655.35S	0.01S	2.00S	×
P2.12	Reservation				
P2.13	Maximum Permitted Temperature	0.0 ~ 2000.0°C	0.1°C	2000.0°C	×
P2.14	Integral Mode	0:Normal Mode 1:Integral Separation Mode	1	0	×
P2.15	I separation Minimum Value	0.1°C ~ 【P2.16】	0.1°C	0.1°C	×
P2.16	I separation Maximum Value	【P2.15】 ~ 2000.0°C	0.1°C	2000.0°C	×
P2.17	Proportion-Frequency Adjuster	0.01~655.35	0.1	Machine Leading	×
P2.18	Integral-Frequency Adjuster	0.001~65.535	0.01	Machine Leading	×
P2.19	Proportion-Power Adjuster	0.01~655.35	0.1	Machine Leading	×

P2.20	Integral-Power Adjuster	0.001~65.535	0.01	Machine Leading	×
P2.21	Proportion-Current Adjuster	0.01~655.35	0.1	Machine Leading	×
<b>P3:Advanced Function Parameter</b>					
P3.00	X3 Switch Option	0: Forbid 1: Valid	1	1	×
P3.01	Test Mode	0 ~ 2	1	1	×
P3.02	Running Limit Code	0 ~ 65535	1	*****	×
P3.03	Running Limit Setting	0: Invalid 1: Valid	1	0	×
P3.04	Limit Running Time Setting	0 ~ 65535H (hour)	1H	0H	×
P3.05	Language	0:English 1:Chinese	1	0	×
P3.06	TC type selection	0: K type 1: Infrared	1	0	×
P3.07	Voltage Correction Coefficient	80.00% ~ 120.00%	0.01%	100.00%	×
P3.08	Input Current Correction Coefficient	80.00% ~ 120.00%	0.01%	100.00%	×
P3.09	Keyboard version	1.00~9.99	0.01	Keyboard set	◆
P3.10	RS485	0: RS485 OFF    1: RS485 ON	1	0	○
P3.11	4-20mA mode choice	0: Invalid    1: Valid	1	0	○
P3.12	The switch of A-07	0: Forbid    1: Valid	1	1	○
P3.13	E-15 Mode	0: Restart    1: Continue	1	0	○
P3.14	Infrared Min-Temperature	0~2000℃	1℃	0℃	○
P3.15	Infrared Max-Temperature	0~2000℃	1℃	1300℃	○
P3.16	Infrared Temperature Correction	0.500~1.500	0.001	1.000	○
P3.17	Max Sink Temperature	60.0~85.0℃	0.1℃	70.0℃	○

## 7.2 Monitoring Parameter Table

Users can observe induction heating equipment running parameters through the keyboard

Monitoring parameter		
Monitoring Code	Instructions	Range
D-00	Input Power	0.00 ~ 655.35kW
D-01	Input Voltage	0 ~ 1000V
D-02	Input Current	0.1 ~ 6553.5A
D-03	Output Frequency	0.50 ~ 40.00KHz
D-04	Total Output Current	0.1 ~ 6553.5A
D-05	Output Current 1	0.1 ~ 6553.5A
D-06	Output Current 2	0.1 ~ 6553.5A
D-07	Resonant CAP Volt	0 ~ 6000V
D-08	Equal Resistance (ESR)	0.0 ~ 100.0Ω
D-09	Inductance	1 ~ 1000uH
D-10	Output Duty Cycle	0.01% ~ 100.00%
D-11	Power Factor Angle	0.0 ~ 180.0°
D-12	Quality Factor Q	0.1 ~ 10.000
D-13	Heat Sink Temperature	0.0 ~ 165.0°C
D-14	AI State	0~4096
D-15	Transformer TEMP	0.0 ~ 165.0°C
D-16	Reservation	
D-17	Run Time (low)	0 ~ 9999H
D-18	Run Time (high)	0 ~ 9999*10000H
D-19	Limit Run Time	0 ~ 9999H
D-20	Special Product Num	1 ~ 65535
D-21	Reservation	
D-22	Error1	No Fault
D-23	Error2	No Fault
D-24	Error3	No Fault
D-25	Error4	No Fault
D-26	Error5	No Fault
D-27	Error6	No Fault
D-28	Error7	No Fault
D-29	Error8	No Fault
D-30	Error9	No Fault
D-31	Error10	No Fault

## 8. Protection、 Alarm Code and Fault Check

### 8.1 Protection and Alarm Code Table

Fault Code			
Fault Code	Fault Instruction	Reason	Fault Inspection
E-00	No Protection Action		
E-01	Busbar OverCurrent Protection	Busbar overCurrent circuit protect action	1.Stop or single machine running with error code E-01, try to replace control board. Multi heating machine with one load, try to increase the distance between coils
E-02	Output OverCurrent Protection	Output overCurrent circuit protect	1.Inspect the output terminal and coil whether short or not 2.Inspect output terminal, coil and machine inwall whether there are signs of ignition, or should strengthen the insulativity between output coil and connection point. 3.Multi heating machine with one load, try to increase the distance between coils.
E-03	VCE Inspection Protection	Drive circuit protection action	1.Inspect output terminal and coil whether short circuit or not 2.Inspect output terminal, coil and machine inwall whether there are signs of ignition, or should strengthen the insulativity between output coil and connection point. 3.Inspect output terminal, coil and machine inwall whether there are signs of ignition, or should strengthen the insulativity between output coil and connection point. 4.Power on with error code E-03 , contact with the manufacture.
E-04	Output Software OverCurrent	Output Current overload protection software action	1.Inspect the output terminal and coil whether short or not 2.Inspect output terminal, coil and machine inwall whether there are signs of ignition, or should

			strengthen the insulativity between output coil and connection point.
E-05	Input Busbar Overvoltage Protection	Output overvoltage protection software action	<ol style="list-style-type: none"> <li>1.After stop, use multimeter to measure input cable voltage, ensure it in the range of <math>V_e^*</math> (<math>1\pm 20\%</math>)</li> <li>2.After stop, use multimeter to measure input cable voltage, ensure it in the range of <math>\{V_e^* (1\pm 20\%)\}</math>, then adjust P3.07 value to ensure D-01value=cable voltage</li> <li>3.Multi heating machine with one load, error code with E-05, try to increase the distance between coils.</li> </ol>
E-06	Input Busbar Undervoltage Protection	Output undervoltage protection software action	<ol style="list-style-type: none"> <li>1.After stop, use multimeter to measure input cable voltage, ensure it in the range of <math>V_e^*</math> (<math>1\pm 20\%</math>)</li> <li>2.After stop, use multimeter to measure input cable voltage, ensure it in the range of <math>\{V_e^* (1\pm 20\%)\}</math>, then adjust P3.07 value to ensure D-01value=cable voltage</li> </ol>
E-07	Reservation		
E-08	Reservation		
E-09	Default Phase Protection (only for 3phases input power)	3 Phases AC default phase protection action	<ol style="list-style-type: none"> <li>1.Tighten the screws on the input terminal of the heating power machine, ensure contact between input line and input terminal well</li> <li>2.Check 3-phase input power line whether broken, or replace the lines.</li> <li>3.Check creepage</li> </ol>
E-10	Radiator Temperature Overhigh	<ol style="list-style-type: none"> <li>①air flue jam</li> <li>②inverter fan fault</li> <li>③ambient temperature overhigh</li> </ol>	<ol style="list-style-type: none"> <li>1.Clean cooling fan</li> <li>2.Improve radiating ambient</li> <li>3.Check fan power line whether contact well</li> <li>4.Replace fans if broken</li> </ol>
NOTE: $V_e$ as rated input voltage			
E-11	Overload Protection	Load power overhigh	Input power set value $\leq$ rated

			power
E-12	Load Temperature Overhigh Protection	Temperature adjustment not stable or temperature sensor broken	Inspect load temperature sampling channel
E-13	Reservation		
E-14	Busbar Current Overload During Running (software protection point) Protection	Busbar end Current protection software action	Inspect input voltage whether abnormal or not
E-15	External Equipment Fault	External fault Signal input	Inspect external equipment fault
E-16	No-load Running Protection	No-load running	1.no-connect with heating coil 2.output coil and output terminal with poor contact
E-17	Reservation		
E-18	Reservation		
E-19	Reservation		
E-20	Reservation		
E-21	Running Time Limitation Protection	Limit running function in effect and set time up	Input running limit code (P3.02) to check and set P3.03 to 0
E-22	Display Panel Communication Fault	Display Panel line Connected bad, control board broken	1.Reinsert keyboard board and control board communication line 2.Take keyboard board out from the slot and reinstall it. 3.Replace keyboard board and control board communication line 4.Try to replace a new control board
E-23	Load Inductance Overhigh Protection	Load inductance overhigh	Reduce output coil inductance
E-24	Load Inductance End-Low Protection	Load inductance end-low	Increase output coil inductance
E-25	Creepage Protection	Induction heating power creepage	1.Check whether the coil is creepage 2.Check whether coil directly contact with iron material

			3. Check whether machine with signs of lighter
E-26	Transformer TEMP Overhigh Protection	Hydraulic pressure low or temperature sensor broken	
E-27	Cooling system fault	Bad connect of transformer cooling pipe, or too many dirt, or water pressure switch fault	1. Check water quality and clean dirt; 2. Check water pressure switch.
E-28	Resonant CAP TEMP Overhigh Protection	CAP not matched or Fan Power End-Low	
E-29	Resonant CAP Temperature Measuring Fault Protection	Resonant capacitance temperature measuring line not connected well	
E-30	Load Coil Temperature Measuring Fault Protection	Load coil temperature measuring line not connected well	
E-31	Transformer Temperature Measuring Fault Protection	Transformer temperature measuring line not connected well	
E-32	PID Feedback Fault	Temperature PID feedback line not connected well or disconnected	
E-33	Slave Machine Synchronization Running Fault Protection	Slave machine under protection or without synchronous running mode	
P.oFF	Low Voltage	Busbar voltage too low, raise supply power voltage	1. After stop, use multimeter to measure input cable voltage, ensure it in the range of $V_e^* (1 \pm 20\%)$ 2. After stop, use multimeter to measure input cable voltage, ensure it in the range of $\{V_e^* (1 \pm 20\%)\}$ , then adjust P3.07 value to ensure D-01 value=cable voltage

<b>Alarm Code</b>			
<b>Alarm Code</b>	<b>Instruction</b>	<b>Reason</b>	<b>Fault Inspection</b>
A1	No Load or Can Not Detect load		
A2	Current Limit	Input (output) Current Higher than rated Input (output) Current protection	
A3	Derating Power Running	①voltage low, in the scope of $\pm$ (20 ~ 30%) ②radiator temperature overhigh lead to forced derating power running	if machine temperature overhigh, increase power ambient ventilation and clean radiating fan
A4	Voltage High Alarm	Input voltage higher Than input voltage protection value	Ensure D-02 value=cable voltage
A5	Voltage Low Alarm	Input voltage lower than input voltage protection value	Adjust P3.06, ensure D-02 value=cable voltage
A6	Transformer And Master Control Panel Communication Fault Alarm	Transformer and master control panel Communication fault	1.Check transformer and master control panel connection well or not 2.Check transformer indicator Whether normal
A7	PID Feedback Offline		
A8	Load Coil Temperature Measuring Offline		
A9	Transformer Temperature Measuring Offline		
A10	Resonant CAP Temperature Measuring Offline		
A11	Synchronous Running mode Communication Fault alarm	Synchronous running mode communication line connected bad	Check synchronous running mode Communication line

## 9. Water Cooling System Operation Manual



### 9.1 Function introduction:

Below items introduction:

Ts: (water tank) setting temperature (this temperature is adjustable, please see below control panel introduction)

Tw: (water tank) real temperature

#### 9.1.1 Operation:

1) Compressor start and stop:

Refrigeration mode: when  $Tw \geq Ts$ , compressor start.

when  $Tw \leq Ts - \text{temp.difference}$  (temp.difference is adjustable)

Bypass mode: compressor stop time  $\geq 60S$ , the compressor start and running

2) chiller starting process

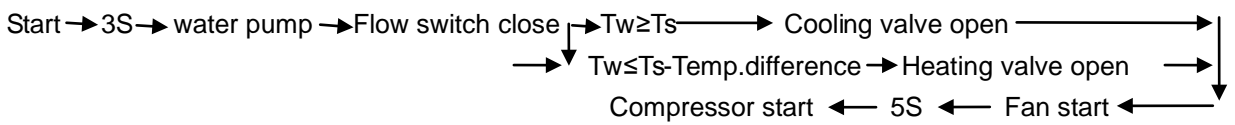

3) Chiller shut off process

Shut off → all shut off

4) water pump running

when chiller starting, the water pump running, it keeps running while chiller running

5) Fan start and stop

5S before compressor start, the fan start running, 5S after compressor shut off, the fan shut off

6) error output

When error happened, the output error code will display on the control panel

### 9.2 protection

1) compressor start and stop protection

The compressor should restart again at least after 90S. The compressor running at least 60S to shut off except the chiller shut off and error.

2) high pressure protection

After compressor starting, then check the high pressure switch. If high pressure last break 1S to enter into alarm mode. once confirmed high pressure protection to lock this error and stop all signal output, no matter its reset or not will display the error code.

3) low pressure protection

After compressor starting to delay 30S for checking, if low pressure switch break 3S to enter into alarm mode, once confirmed low pressure to lock this error and stop all signal output, no matter its reset or not will display the error code.

4) water flow protection

After water pump running 3S to check water flow switch, if water flow switch cut off to

enter into alarm mode, once confirmed water flow protection to lock this error and stop all signals output, no matter its reset or not will display the error code.

5) water level protection

If water level switch shut off(or water lacking),the chiller unit will shut off.

6) compressor overload protection

After compressor starting 6S to check the Current,if Current over the setting value and last 5S to stop all signals output.

Note:if no need compressor overload protection can set the basic Current 0,please refer below parameter setting.

7) power supply 3 phases missing phase and reverse phase protection

When 3 phases power B phase,C phase out of phase or A B C wrong phase, stop all signals output. Error output and display error code.

Note: if single phase 220V usage, should set it into 00,please refer below parameter setting.

8) over temperature protection

When water temperature beyond up setting value or below down setting valve, stop all signals output.error output and display error code.

9) temperature sensor protection

When temperature sensor short/off circuit,stop all chiller parts. Error output and display error code.

NOTE: Must shut off electricity power supply to stop chiller once alarming to check and prepare the chiller.

### 9.3 control panel introduction

1) operation panel diagram and introduction

- ①— LED display window
- ②— setting mode indicator
- ③— rising (+) keys
- ④— Menu / confirm
- ⑤— falling (-) keys
- ⑥— return / start or stop keys

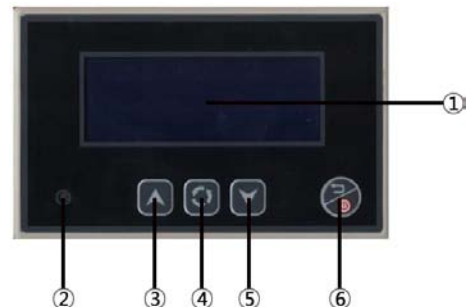

2) on/off operation process

Chiller power on, power supply indicator lighting,press ON/OFF to control chiller system start and stop.when chiller starting, PV display the real water temperature,SV display the setting water temperature.Running indicator light flashing,and after compressor starting,the running indicator keep lighting,chiller system enter into normal working state.

3) parameter setting

① user parameter setting

Press SET for 3 seconds, the control panel enter into water temperature setting, water temperature indicator lighting,SV displays the setting number, press UP and DOWN to adjust,press SET to shift into DT setting.

After Parameter setting finished,press ON/OFF to confirm and exit.if there is no press within 5 seconds,the control panel will keep the setting number and exit the setting status.

② administer parameters setting

Continuous Press FUNC for 5 seconds while chiller on power off status,PV display “cod” and SV display “000”to remind input the password,press UP and DOWN to input the password NO.and press SET to shift ten digit and single digit to input. After input correct password,press ON/OFF to enter into administer parameters setting. Meanwhile PV displays P1 means enter into Phase protection choice, SV displays setting value. Press UP or DOWN to adjust,press SET shift to next item parameter setting. Press ON/OFF to confirm and exit if parameter setting finished. Exit the setting If input wrong password.(Password 359).

**Specifications setting table:**

Specifications	NO	Items	unit	setting range	step	default value	
User parameters	1	Set temp	°C	2.0~45.0	0.1	25.0	
	2	Set diff	°C	0.1~8.0	0.1	2	
	3	Follow temp	°C	-20.0—20.0	0.1	20	
Admi parameter	4	phase enable	disable			enable	
			enable				
	5	1#Comp Current	A	0~30	1	14	
	6	2#Comp Current	A	0~30	1	14	
	7	upper limit temp	°C	25~75	0.1	50.0	
	8	lower limit temp	°C	-20~10.0	0.1	5.0	
	9	Comp selection	Double head				Double head
			1#head				
			2#head				
	10	Liquid level detection	disable				enable
enable							
11	Off state memory	No memory				No memory	
		memory					
12	compressor delay	S	60-600	1	90		
13	Mode selection	Temp fixed				Temp fixed	
		Envi foll mode					
sys. parameter	14	Backlight time delay	S	0-600	1	60	
	15	date	2014-01-01---3000-12-31			2015-12-29	
	16	Language select	Chinese				English
English							

**Note: display water tank temp.= measure temp.+correction temp.value**

### 9.4 compressor Current and condensing temp.inquiry

Press UP and DOWN to checking compressor operating Current when chiller starting,Nixie tube ④ display the inquiry location,Nixie tube ⑤ display the inquiry value.if there is no press within 3 seconds,the control panel will auto-back to display water temp. and temp.setting status.

CH0 ----- water tank temp.

CH1 ----- compressor Current

### 9.5 error output

All stop and output the alarm signal if there is any error and display the error code.

#### error code table:

NO.	Code	error
1	E02	temp.sensor error (open circuit or short circuit)
2	E08	power supply phase missing or reverse phase
3	E09	compressor Current beyond
4	E10	water level switch cut off (water lacking error)
5	E11	compressor low pressure error
6	E12	compressor high pressure error
7	E13	water flow switch error
8	E45	water temp.beyond up limited value
9	E54	water temp.lower than low limited value